

1
2
3
4
5
6
7
8
9
10
11
12
13
14
15
16
17
18
19
20
21
22
23
24
25
26
27
28
29
30
31



Pharmaceutical Development Case Study: “ACE Tablets”

Prepared by CMC-IM Working Group
March 13, 2008

Version 2.0

Intended for Distribution

32
33
34

CONTENTS

35	Foreword.....	8
36	Acknowledgements	9
37	1. Report on the Pharmaceutical Development of Acetripitan Tablets	10
38	1.1 Introduction and Overview	10
39	1.2 Target Product Profile.....	10
40	1.3 Formulation and Pharmaceutical Manufacturing Selection	12
41	1.4 Control Strategy.....	13
42	2. Selection of the Components of the Drug Product.....	14
43	2.1 Drug Substance	14
44	2.2 Excipients.....	14
45	3. Drug Product Formulation Development.....	16
46	3.1. Formulation Development Overview	16
47	3.2 Development of a Discriminatory Dissolution Method	17
48	3.3. Biopharmaceutics and Pharmacokinetics of ACE.....	18
49	3.4 Prototype Formulation and Process Selection	18
50	<i>3.4.A Formulation Component Level Definition Study.....</i>	<i>20</i>
51	<i>3.4.B API Particle Size and Magnesium Stearate Interaction Study.....</i>	<i>25</i>
52	3.5 Summary of Formulation Component Studies	28
53	4. Manufacturing Process Development	29
54	4.1 Overview	29
55	<i>4.1.A Summary of the selected process</i>	<i>29</i>
56	4.2 Process Optimization – Blending Unit Operation.....	31
57	<i>4.2.A Method for Determining Blend Homogeneity.....</i>	<i>31</i>

58	<i>4.2.B Critical Parameters Affecting the blend homogeneity</i>	32
59	<i>4.2.C Scale-up of the Blending Process</i>	35
60	<i>4.2.D Conclusion for Blending</i>	36
61	4.3 Process Optimization – Roller Compaction Unit Operation	37
62	<i>4.3.A Introduction</i>	37
63	<i>4.3.B Failure Modes, Effects and Criticality Analysis (FMECA) approach to</i>	
64	<i>Roller Compaction</i>	38
65	<i>4.3.C Initial Quality Risk Assessment (QRA-1) for the roller compaction and</i>	
66	<i>milling stages</i>	38
67	<i>4.3.D Process Development Work</i>	40
68	<i>4.3.E DoE-2: Roller compaction response surface</i>	46
69	<i>4.3.F Roller Compaction and Milling Conclusions</i>	51
70	<i>4.3 G Second Risk Assessment for Compaction and Milling (QRA-2)</i>	53
71	4.4 Process Optimization – Lubrication Unit Operation	55
72	<i>4.4 A Lubrication Blending</i>	55
73	4.5 Process Optimization – Tablet Compression Unit Operation	58
74	<i>4.5.A Introduction</i>	58
75	<i>4.5.B Compression DoE 2</i>	61
76	<i>4.5.C Compression DoE 3</i>	68
77	4.6 The In vivo investigation	75
78	<i>4.6.A Rationale for study ACEPK0015</i>	75
79	<i>4.6.B Clinical pharmacokinetic study (ACEPK0015)</i>	75
80	<i>4.6.C Results</i>	76
81	<i>4.6.D Exploration of an in vitro-in vivo correlation for ACE tablets</i>	78
82	4.7 Summary Control Strategy for the ACE Tablets Manufacturing Process	79
83	<i>4.7.A Overview</i>	79

84	<i>4.7.B Unit Operation Control Strategy</i>	82
85	<i>4.7.C Control of Drug Product Critical Quality Attributes</i>	85
86	<i>4.7.D Control Strategy Conclusion</i>	87
87	5. Container Closure System	87
88	6. Microbiological Attributes	87
89	7. Summary of the Manufacturing Procedure	88
90	7.1 Manufacturing Formula for ACE 20 mg Tablets	88
91	7.2 Description of Manufacturing Process and Process Controls for ACE, IR	
92	Tablets	89
93	<i>7.2.A Process Flow Diagram</i>	89
94	7.3 Description of Manufacturing Process	89
95	7.4 Primary packaging	91
96	8. Control of Critical Steps and Intermediates for ACE Tablets	91
97	8.1 Control of Drug Product	91
98	<i>8.1.A Specification for ACE 20 mg Tablets</i>	91
99		

100	LIST OF FIGURES	
101		
102	Figure 1: Plot of % Target Tablet Weight vs % Label Claim for Individual Tablets Tested	
103	from Formulation Definition Study	22
104	Figure 2: Interaction profile for Hardness Response at Fixed Compression Pressure.	22
105	Figure 3: Interaction Profile for Dissolution Response at a Set Target Tablet Hardness of	
106	12kP.	23
107	Figure 4: Contour plot of Dissolution response for 10% drug load at a set Target Tablet	
108	Hardness of 12kP	24
109	Figure 5: Interaction profile for Weight %RSD Response at Fixed Compression Pressure.	
110	25
111	Figure 6: Interaction profile for Hardness Response at Fixed Compression Pressure.	26
112	Figure 7: Interaction profile for Tablet Weight % RSD Response at Fixed Compression	
113	Pressure.....	27
114	Figure 8: Contour Plot of Dissolution at a Set Target Tablet Hardness of 12kP.....	28
115	Figure 9: Manufacturing Process Flow for ACE tablets.....	30
116	Figure 10: Correlation of Blend NIR CV with Tablet Content Uniformity RSD.....	32
117	Figure 11: Cause and Effect Diagram for Blend Uniformity	32
118	Figure 12: Blend Contour plots.....	34
119	Figure 13: NIR output of DoE Blending Experiments (Representative Results)	34
120	Figure 14: Blending Control Data.....	36
121	Figure 15: Process Map for Roller Compaction and Milling	38
122	Figure 16: Initial Quality Risk Assessment (QRA-1) for the Roller Compaction and	
123	Milling stages.....	39
124	Figure 17: Half-normal Plot and ANOVA for Effects on Ribbon Density	42
125	Figure 18: Relationship between Roller Pressure and Ribbon Density	43
126	Figure 19: Half-normal Plot and ANOVA for Effects on GSA.....	44
127	Figure 20: The Effects of Mill Screen Size and Mill Speed (600 or 1200 rpm) on GSA..	45
128	Figure 21: Half-normal plot and ANOVA for effects on tablet dissolution	46
129	Figure 22: Contour plot for API particle size and roller pressure versus tablet dissolution	
130	(% at 30 mins) with a 1% magnesium stearate level	47
131	Figure 23: Contour plot for API particle size and roller pressure versus tablet dissolution	
132	(% at 30 min) with a 1.5% magnesium stearate level.....	48
133	Figure 24: Contour plot for API particle size and roller pressure versus tablet dissolution	
134	(% at 30 min) with a 2% magnesium stearate level.....	48
135	Figure 25: Confirmed Linear Relationship between Roller Pressure and Ribbon Density	49
136	Figure 26: Description of Parameters associated with Roller Compactor	50
137	Figure 27: Scale independent Relationship Illustration	51
138	Figure 28: Roller Compaction: Summary of Cause and Effect Relationships identified	
139	from Process Development Studies	52
140	Figure 29: NIR in-process control feedback loop.....	53
141	Figure 30: Final Risk Assessment (QRA-2) for the Roller Compaction and Milling Stages	
142	54
143	Figure 31: Effect of Blending Parameters on Tablet Hardness	57
144	Figure 32: Effect of Blending Parameters on Drug Release at 30min.....	57
145	Figure 33: ACE Tablet Compression Process Flow	59

146	Figure 34: IPO Diagram for ACE Compression Step.....	60
147	Figure 35: Effect of Compression Force on Tablet Hardness.....	63
148	Figure 36: Effect of Compression Force on Tablet Dissolution at 15min.....	65
149	Figure 37: Correlation between Tablet Hardness and Dissolution at 15 Minutes	65
150	Figure 38: Effect of Compression Force on Tablet Dissolution at 30min.....	66
151	Figure 39: Correlation between Tablet Hardness and Dissolution at 30 Minutes	66
152	Figure 40: Correlation between Disintegration Time and Dissolution at 30min.....	67
153	Figure 41: Example Plots of Dissolution versus Hardness for Different Tablet Variants.	70
154	Figure 42: Tablet Content Uniformity: data plot for one of six tablet batches.....	71
155	Figure 43: Plot of %Target Weight versus % label Claim.....	72
156	Figure 44: Representation of Proven Acceptable Ranges for Compression.....	73
157	Figure 45: Average dissolution of all 5 tablet variants in the 1% SLS method.....	77
158	Figure 46: Average plasma concentration-time profiles (0 to 48 hrs) for 20 mg ACE IR	
159	variants and oral solution (geomean, n=12).....	79
160	Figure 47: Control Strategy for CQAs for ACE Tablets	82
161	Figure 48: Control Strategy for Blending	83
162	Figure 49: Control Strategy for Roller Compaction	84
163	Figure 50: Control Strategy for Compression.....	85
164		
165		

166
167
168
169
170
171
172
173
174
175
176
177
178
179
180
181
182
183
184
185
186
187
188
189
190
191
192
193
194
195
196
197
198
199
200
201
202
203
204
205
206
207
208

LIST OF TABLES

Table 1: Target Product Profile.....	11
Table 2: Risk Assessment to Identify Variables Potentially Impacting Product Quality ..	12
Table 3: Potential impact of API Attributes on Drug Product Attributes.....	14
Table 4: Excipients in ACE tablets.....	15
Table 5: Potential impact of Excipients on Drug Product CQAs	16
Table 6: Formulation Composition Risk Assessment.....	20
Table 7: Risk Matrix for Drug Product CQAs for each unit operation	30
Table 8: Process Parameter Ranges for Blending.....	31
Table 9: Risk Matrix Table for Blending Unit Operation.....	33
Table 10: Summary of Scale Up Blending Parameters	35
Table 11: Input attributes for Blending Operation.....	36
Table 12: Risk Matrix Table for Blending Unit Operation after Controls	37
Table 13: Process Parameter Targets for Lubrication.....	55
Table 14: Cause and Effect Matrix Risk Analysis for Lubrication	55
Table 15: DoE Results: AQL Observations as a Response to Fill Ratio and Number of Revolutions (<25 cosmetic observations acceptable)	56
Table 16: Cause and Effect Matrix Risk Analysis for Lubrication	58
Table 17: Summary of Scale Up Lubrication Parameters	58
Table 18: Summary of High Potential Risks from ACE Compression Step FMEA .	60
Table 19: Potentially Important Compression Process Variables and Quality Attributes.	61
Table 20: Process parameters ranges investigated in compression DoE 2	62
Table 21: Effect tests for Hardness.....	63
Table 22: Effect tests for 15min Dissolution	64
Table 23: Effect tests for 30min Dissolution	65
Table 24: Effect tests for Disintegration Time	67
Table 25: Output Attributes for Compression Unit Operation	68
Table 26: Input variables and process parameter ranges investigated.....	69
Table 27: Example compression process operating conditions	70
Table 28: Updated Compaction FMEA	74
Table 29: Composition of ACE 20mg Tablets used in Study ACECPK00015.....	76
Table 30: Mean Pharmacokinetic Parameters for the ACE Tablet Variants ($AUC_{0-\infty}$, C_{max} , t_{max} and $t_{1/2}$) all represented as Geometric Mean Values	78
Table 31: Overall Risk Assessment Updated in line with Process Understanding Developed	80
Table 32: Summary of overall Design Space for ACE tablets	81
Table 33: Manufacturing Formula for ACE 20 mg Tablets	88
Table 34. Critical Process Steps and associated Intermediates.....	91
Table 35. Specification for ACE 20 mg Tablets.....	92

209

210 **Foreword**

211

212 The last decade has seen a significant transformation in pharmaceutical quality regulation
213 from an empirical process to a more science and risk based approach. This case study is
214 an extremely important document for helping guide FDA and the industry toward the
215 “desired state” of pharmaceutical quality envisioned for the 21st Century. It is through
216 this and similar documents that we can determine how best to implement the principles of
217 ICH Q8, Q9, and Q10 to meet the requirements of this new regulatory paradigm.

218

219 I believe this case study, and others like it, will provide a foundation for discussion with
220 our scientific and regulatory constituents within industry and with our global regulatory
221 colleagues in other agencies. Such documents are necessary to enable dialogue and
222 understanding of what we all mean and expect from the ICH paradigms, and to ensure an
223 appropriate framework for future regulatory processes, including both review and
224 inspection of all pharmaceuticals. Not only does this case study provide a basis for
225 understanding and commitment to the process, it also helps identify the opportunities that
226 can be gained through the enhanced scientific experience and knowledge sharing.

227

228 I want to personally thank Conformia, FDA’s CRADA partner, the CMC-IM Working
229 Group team that Conformia convened and all of those individuals who contributed to
230 creating this Pharmaceutical Development Case Study on ACE Tablets . I truly believe
231 that it will be invaluable to all of us in moving forward in implementing a modern
232 approach to the regulatory processes. This case study is a perfect example of how
233 scientific collaboration can lead to synergism across our regulatory programs in order to
234 better serve the public.

235

236 *Helen Winkle, Director, Office of Pharmaceutical Sciences, CDER, FDA*

237

238

239 Acknowledgements

240

241 The acetriptan tablets (ACE) case study that follows is the first deliverable from
242 an industry led, not-for profit, working group focused on two areas of
243 implementation around the ICH Quality vision: track 1) a chemistry,
244 manufacturing and controls focus and track 2) an information management /
245 knowledge management focus. This group, called the CMC-IM Working group, is
246 comprised of Abbott Laboratories (Abbott), AstraZeneca (AZ), Conformia, Eli
247 Lilly and Company (Eli Lilly), GlaxoSmithKline (GSK) and IBM Global Business
248 Services (IBM).

249

250 Special thanks are due to the CMC-IM Working Group members who helped
251 author “ACE”: Liam Feely (Abbott), Ken Cline (Abbott), Steve Laurenz (Abbott)
252 Shuhong Zhang (Abbott), Julie Garren (Abbott), Mike Hannay (AZ), Anna Ahern
253 (AZ) Bryan Mobbs (AZ), John Smart (AZ), Liuda Shtohryn (AZ), John Berridge
254 (Conformia), Vineet Gulati (Conformia), Anjali Kataria (Conformia), Ken Morris
255 (Conformia), Joe Prang (Conformia), Sam Venugopal (Conformia), David
256 Maclaren (Eli Lilly), Jeff Hofer (Eli Lilly), Eric Jensen (Eli Lilly), Lindsay Wylie
257 (GSK), Norma Collinsworth (GSK), Jo Craig (GSK), Vance Novak (GSK), Ray
258 Stevens (GSK), Richard Young (GSK), Dennis Bell (IBM), Marc Weisenberg
259 (IBM) and Charlie Honke (IBM).

260

261 We also acknowledge EFPIA’s Exemplar mock P2 discussion paper, which gave
262 us the ability to see that a more comprehensive case study could be used to
263 improve transparency and change the nature of dialogue between industry
264 and regulators.

265

266 *Anjali Kataria, Chief Marketing Officer and Founder of Conformia*
267 *Principal Investigator, FDA-Conformia CRADA*

268

269 **1. Report on the Pharmaceutical Development of Acetripitan** 270 **Tablets**

271 ***1.1 Introduction and Overview***

272

273 This report presents a summary of the pharmaceutical development of acetripitan (“ACE”)
274 tablets. It emphasizes a science and risk-based approach to product and process
275 development, and presents findings as a knowledge-based report. Where relevant,
276 supporting data have been summarized in appropriate tables or illustrations
277

278 The scientific approach used begins with identification of the desired dosage form and
279 performance attributes through the target product profile. From this target product profile,
280 an initial list of critical quality attributes was developed. A risk assessment was
281 undertaken to identify the variables and unit operations which are most likely to impact
282 the critical quality attributes. This was then used to focus development activities on
283 potential high risk areas. A risk assessment, starting with the physico-chemical
284 characteristics of the API, led to the identification of a viable formulation and
285 manufacturing approach. Formulation development involved the use of prior knowledge
286 and structured experimentation to investigate the relationship between formulation
287 component levels, API attributes and the drug product quality attributes. An interaction
288 between API particle size and magnesium stearate level was demonstrated and acceptable
289 formulation component levels and API particle size ranges were identified. Development
290 of the manufacturing process focused on the unit operations posing greatest potential risk
291 to drug product quality. Using prior knowledge, models, extrapolation and risk assessment
292 processes, the material attributes and process parameters, which could have an impact
293 upon final product quality, were identified. For each unit operation experimentation was
294 undertaken to define the relationship between the input attributes, process parameters,
295 output attributes and final drug product quality. The intermediate critical quality
296 attributes, operating conditions and a control strategy were defined to mitigate risk and
297 ensure final product quality. An *in-vivo* study was then conducted to compare formulation
298 and manufacturing variables. This study revealed that the dissolution test procedure
299 provided excellent prediction of biopharmaceutical performance, but that the initial
300 acceptance criterion needed to be modified. Based on the pharmaceutical development
301 work and *in-vivo* results, a design space and science and risk-based approaches to
302 formulation component level adjustment, scale-up, site transfers and ‘real time release’
303 are proposed based on the enhanced product and process understanding.

304 ***1.2 Target Product Profile***

305 ACE tablets are being developed for the treatment of migraine. The intent is to develop a
306 rapid onset therapy which will provide relief of the symptoms of migraine.
307

308 The pharmaceutical target profile for acetripitan is a safe efficacious convenient dosage
309 form, preferably a tablet, that will facilitate patient compliance. The tablet should be of an

310 appropriate size, with a single tablet per dose. The manufacturing process for the tablet
 311 should be robust and reproducible, and should result in a product that meets the
 312 appropriate drug product critical quality attributes, for example identity, assay,
 313 appearance, chemical and microbiological purity, disintegration and/or dissolution as well
 314 as content uniformity. The drug product should be packaged in a container closure system
 315 that will provide adequate protection from moisture vapour, protection through
 316 distribution and use as well as convenience of use for the patient.

317
 318 A Target Product Profile is presented in the **Table 1:** below. From the profile, the initial
 319 Critical Quality Attributes which were used to define satisfactory quality were identified.

321 **Table 1:Target Product Profile**

322

Quality Attribute	Target	Criticality
Dosage form	Tablet, maximum weight 200mg	Not applicable
Potency	20 mg	Not applicable
Pharmacokinetics	Immediate release enabling Tmax in 2 hours or less	Related to dissolution
Appearance	Tablet conforming to description shape and size	Critical
Identity	Positive for acetriptan	Critical
Assay	95 – 105%	Critical
Impurities	ACE12345 NMT 0.5%, other impurities NMT 0.2%, total NMT 1%	Critical
Water	NMT 1%	Not critical – API not sensitive to hydrolysis
Content Uniformity	Meets USP	Critical
Resistance to Crushing (Hardness)	5-12kP	Not critical since related to dissolution
Friability	NMT 1.0%	Not critical
Dissolution	Consistent with immediate release, e.g., NLT 75% at 30mins	Critical
Disintegration	NMT 15mins	Not critical, a precursor to dissolution
Microbiology	If testing required, meets USP criteria	Critical only if drug product supports microbial growth

323

324 **1.3 Formulation and Pharmaceutical Manufacturing Selection**

 325 The formulation type chosen was an oral standard release tablet, in consideration of the
 326 known PK characteristics of the molecule. A rapid onset is desirable for the treatment of
 327 migraine and a T_{max} of less than 2 hours was desired, and subsequently achieved, with this
 328 formulation.

 329
 330 A roller compaction granulation process was chosen based on prior scientific knowledge
 331 of products with similar physical and chemical properties, and available technologies and
 332 equipment. Factors that influenced the selection of a roller compaction process were: 1)
 333 degradation of the drug on exposure to heat precluding drying following wet granulation,
 334 and 2) poor flow properties precluding direct compression. Thermal degradation also
 335 precluded drying following film coating. Roller compaction was also chosen in the
 336 expectation of its meeting the expectation of its suitability for operating with excipients
 337 which are compatible with acetriptyan, active pharmaceutical ingredient (API)
 338 processability and API stability requirements during manufacture, and since it should
 339 result in a tablet that will have a shelf life of at least 2 years.

 340
 341 The development of ACE tablets and the associated manufacturing process used prior
 342 knowledge from previous products and development projects. A risk analysis, in
 343 accordance with ICH Q9, was used to establish which variables and unit operations were
 344 likely to have the greatest impact on product quality. This initial risk assessment is shown
 345 in **Table 2** below.

 347 **Table 2: Risk Assessment to Identify Variables Potentially Impacting Product**
 348 **Quality**

	Variables and Unit Operations					
DP CQAs	Formulation Composition	Blending I	Roller Compaction	Milling	Lubrication	Compression
Appearance	Low	Low	Low	Low	High	High
Identity	Low	Low	Low	Low	Low	Low
Assay	Low	Low	Low	Low	Low	High
Impurities	High	Low	Low	Low	Low	Low
Content Uniformity	High	High	High	High	Low	High
Dissolution	High	Low	High	High	High	High

 349
 350

 351 The boxes shaded green were concluded, through prior knowledge, to present low
 352 risk to the product critical quality attributes. The red boxes represent potential risks to the
 353 product and formed areas for further study during development.

354

 355 The proposed commercial formulation is an immediate release tablet. Only one tablet
 356 strength is proposed for commercialization, a 200 mg tablet containing 20 mg of
 357 acetriptyan. Each tablet contains the following excipients: microcrystalline cellulose,
 358 lactose monohydrate, croscarmellose sodium, magnesium stearate and talc. The
 359 manufacturing process involves a preblending step, roller compaction of the acetriptyan

360 with microcrystalline cellulose, croscarmellose sodium, magnesium stearate and lactose
361 monohydrate, then milling to produce granules before blending with magnesium stearate,
362 and talc. This is then followed by compression on a rotary tablet press. ACE tablets are
363 proposed to be supplied as white, biconvex, round tablets containing 20 mg of acetriptan
364 identified with “ACE” and “20” debossed on one side, in cartons containing a blister pack
365 of 6 tablets, or in polypropylene bottles containing 10 tablets. Further information on the
366 packaging is provided under Container Closure System, Section 5.

367
368 For the unit operations with the potential to impact quality, a further risk assessment was
369 used to identify process parameters and materials’ attributes that could impact product
370 quality. Experimental studies were then defined and executed to develop additional
371 scientific knowledge and understanding, to allow appropriate controls to be developed and
372 implemented thereby mitigating the risk to quality.

373 **1.4 Control Strategy**

374
375 Process understanding developed around ACE tablets demonstrated that blending, roller
376 compaction and compression are the critical unit operations that determine the quality of
377 the final product.

378
379 Considerable experimentation has been undertaken to gain process understanding of the
380 blending step. A blending design of experiments was used to determine the impact of API
381 particle size, microcrystalline cellulose particle size and environmental humidity on the
382 blending operation. Blend uniformity was found to be the intermediate critical quality
383 attribute that directly impacts the critical quality attribute of content uniformity. Blend
384 uniformity is monitored and controlled by use of NIR.

385
386 Roller compaction was studied using design of experiments investigating formulation
387 factors and roller compaction process parameters. The design of experiments studies
388 enabled cause and effect relationships to be identified between formulation variables,
389 intermediate attributes, process parameters and final product attributes. Ribbon density
390 was identified as the intermediate critical quality attribute which ensures drug product
391 dissolution criteria are met. Ribbon density is measured in-line by NIR as part of the
392 control strategy.

393
394 The compression design of experiments investigated the impact of input material
395 attributes and compression process parameters on final product attributes and showed that
396 tablet hardness is the output attribute that must be controlled because of its relationship to
397 tablet dissolution, and tablet weight due to its relationship to content uniformity. Control
398 of the compression step is ensured through in-process measurements at regular intervals
399 throughout compression. The tablet weight is controlled via an inferential feedback loop
400 with main compression force and fill-height.

401

402 2. Selection of the Components of the Drug Product

403 2.1 Drug Substance

404 The target product profile for ACE tablets was met by the investigation and selection of
 405 the free base of acetriptan. Acetriptan is a weak base with a pKa of 4.9. It forms
 406 crystalline tartrate, citrate, hydrochloride and sulphate salts. The tartrate and citrate salts
 407 show no solubility advantages. The hydrochloride and sulphate salts showed small
 408 improvements in solubility; but, each showed multiple polymorphic forms. Therefore, the
 409 free base was chosen for further development.

410
 411 **Table 3** shows an evaluation of the API attributes that present a risk with respect to final
 412 drug product quality. Those API attributes considered to have potential for impact on the
 413 product quality are coloured in red. The selection of acetriptan free base and polymorphic
 414 form took into consideration the attributes that could affect the drug product quality. The
 415 impact of the API attributes on drug product quality and the manufacturing process was
 416 evaluated during development and is detailed in Section.3. The API critical Quality
 417 attributes that must be controlled to ensure drug product quality are identity, solid state
 418 form, impurities, water content, residual solvents and particle size. The control strategy
 419 for the API manufacturing process, which ensures that acetriptan with appropriate quality
 420 attributes is produced, is detailed in API development reports.

421
 422 **Table 3: Potential impact of API Attributes on Drug Product Attributes**

423

	API Attribute								
DP CQAs	Particle Size	Salt form	Moisture	Crystallinity	Morphology	Stability	Solvent content	Purity	Solubility
Appearance	Low	Low	Low	Low	Low	Low	Low	Low	Low
Identity	Low	High	Low	Low	High	Low	Low	Low	Low
Assay	Low	Low	Low	Low	Low	Low	Low	High	Low
Impurities	Low	Low	High	Low	Low	High	High	High	Low
Content	High	Low	Low	Low	Low	Low	Low	Low	Low
Uniformity	High	Low	Low	Low	Low	Low	Low	Low	Low
Dissolution	High	High	Low	High	High	Low	Low	Low	High

424
 425

426 2.2 Excipients

427

428 In order to meet the target product profile, tablet excipients with appropriate
 429 functionality were assessed based on scientific and prior knowledge. From IND 2-1234,
 430 dated February 30, 2007, the chosen excipients had been used successfully for a roller
 431 compacted formulation of an analogous agent. The excipients selected were
 432 microcrystalline cellulose, lactose monohydrate, croscarmellose sodium, magnesium
 433 stearate and talc.

434

435 Drug/excipient compatibility was assessed through HPLC analysis of binary mixtures of
 436 drug to excipient, at a 1:1 ratio in the solid state, stored at 25°C/60% RH and 40°C/75%
 437 RH (open and closed conditions) for 1 month. An interaction was seen with magnesium

438 stearate at 40°C/75% , however it was still used, as the drug-to-magnesium stearate ratio
 439 in the final product is an order of magnitude less, there will be less direct contact when the
 440 drug is diluted with other excipients and magnesium stearate is generally regarded to be a
 441 better lubricant than the standard alternatives. Subsequent assurance of compatibility was
 442 provided by stability data on formulations used in early clinical trials and the ongoing
 443 stability studies on the formulation proposed for commercialization . No compatibility
 444 issues were identified between acetriptan and the excipients in the final drug product.

445
 446 The excipients included in the product for commercialization are listed together, with
 447 their functionalities, in **Table 4**.

448 **Table 4: Excipients in ACE tablets**

449

Excipient	Quantity per tablet (mg)	Quantity per tablet %	Function
Microcrystalline cellulose	80	40	Filler/Diluent
Lactose monohydrate	81.5*	40.75*	Filler/Diluent
Croscarmellose sodium	6-8	3-4	Disintegrant
Magnesium stearate intra-granular	2-4	1-2	Lubricant
extra-granular	0.5	0.25	
Talc	10	5	Glidant
*Quantity adjusted to compensate for amount of croscarmellose sodium and/or magnesium stearate used in order to ensure 200mg overall tablet weight. Each tablet contains 20 mg (10%) acetriptan			

450

451 Based on scientific and prior knowledge of the excipients used in ACE tablets, a risk
 452 assessment was conducted to determine the potential impact of the excipients on final
 453 product quality (see **Table 5**). The excipients identified as high risk were investigated in
 454 more detail throughout the formulation and manufacturing process development. The
 455 excipients used in the formulation for ACE Tablets, are conventional and the amounts per
 456 tablet are generally within standard quantities of usage. The specifications of the inactive
 457 ingredients comply with the United States Pharmacopeia/National Formulary (USP/NF),
 458 European and Japanese pharmacopoeias. Additional controls, above those in the
 459 pharmacopoeia, include particle size limits on the two major excipients (lactose and
 460 microcrystalline cellulose).

461

462 **Table 5: Potential impact of Excipients on Drug Product CQAs**

463

	Formulation Attributes				
DP CQAs	Microcrystalline Cellulose	Lactose Monohydrate	Croscarmellose Sodium	Magnesium stearate	Talc
Appearance	Low	Low	Low	High	Low
Identity	Low	Low	Low	Low	Low
Assay	Low	Low	Low	Low	Low
Impurities	Low	Low	Low	High	Low
Content Uniformity	High	Low	Low	High	Low
Dissolution	Low	Low	High	High	Low

464

 465 **3. Drug Product Formulation Development**

 466 **3.1. Formulation Development Overview**

467

468 The target product profile was to develop an immediate release tablet dosage form for oral
 469 dosing. The formulation should provide an acceptable tablet size. The manufacturing
 470 process must be robust and reproducible. The drug product will have to meet the critical
 471 quality attributes of identity, assay, appearance, impurities, microbiological, dissolution
 472 and content uniformity while also delivering suitable stability in order to not constrain
 473 commercialization in worldwide markets.

474

475 **Identity** – the API must be of the required chemical structure and solid state form in order
 476 to deliver the desired efficacy and safety profile (See ICH Q6A).

477

478 **Assay**- is related to dose delivery to the patient, thus to efficacy and needs to comply with
 479 appropriate limits for drug content (See ICH Q6A).

480

481 **Appearance**- the appearance of the tablets must be acceptable such that the patient will
 482 comply with the dosing regime (See ICH Q6A)

483

484 **Microbiological** – the tablets must conform to relevant microbiological limit tests to
 485 ensure patient safety. During development, it has been demonstrated that the water
 486 activity is below 0.4; therefore, it is too low to support microbial growth.

487

488 **Dissolution** –dissolution needs to comply with the requirement for an immediate release
 489 tablet as dictated by the target product profile. This requirement relates to efficacy of the
 490 product.

491

492 **Content Uniformity** - is related to consistency of the dose delivered to the patient,
 493 thus to efficacy and needs to comply with USP, JP and Ph.Eur acceptance criteria for
 494 Uniformity of Dosage Units.

495

496 **Impurities (including Degradation Product Content)** - may impact patient safety.
497 Compound ACE12345 is the principal degradation product that was demonstrated to
498 form, at low levels, during stability studies. This is an unqualified impurity. Therefore, its
499 levels need to comply with the relevant ICH limits for unqualified, identified impurities.
500 The levels of any unspecified degradation product will need to comply with the relevant
501 ICH identification limits. In order to ensure patient safety, a limit for total degradation
502 products is included.

503 **3.2 Development of a Discriminatory Dissolution Method**

504
505 As acetriptan is a BCS Class II compound displaying poor solubility (less than 0.015
506 mg/mL) across the physiological pH range (see Biopharmaceutics and Pharmacokinetics
507 Section 2.1.3), it was recognized that development of a dissolution method that can act as
508 a surrogate of pharmacokinetics was an important initial step to allow ACE tablets
509 manufactured during development studies to be assessed in terms of *in vivo* performance.
510 If such a test could be established then it could be used to help establish design space(s).
511 By consideration of ICH Q6A guidance, the objective was a dissolution test method:

- 512
- 513 • that was able to distinguish amongst different input material, processing and
514 formulation variables.
 - 515 • that achieved significant (e.g. greater than 75%) dissolution within a timescale
516 appropriate for a routine control test.
 - 517 • that could demonstrate *in vivo* relevance.
- 518

519 A summary of the learning gained from the method development studies is provided
520 below.

521
522 The dissolution of ACE tablets was assessed in aqueous buffers across the pH range 1.2 to
523 6.8. At all of the pH levels investigated, low recoveries were observed due to the low
524 solubility of the 20 mg dose. From these studies, it was concluded that aqueous buffers
525 did not provide the optimum conditions for use as a routine control test capable of
526 differentiation between processing and formulation variables for ACE tablets.

527
528 In accordance with regulatory guidance documents, the use of surfactants was evaluated.
529 The dissolution of ACE tablets was assessed in Tween 80 and sodium lauryl sulphate
530 (SLS). Tween media were considered to be unsuitable due to coning of insoluble tablet
531 excipients leading to incomplete disintegration of ACE tablets. Dissolution in SLS media
532 exhibited the potential for: 1) differentiation between processing and formulation
533 variables, and 2) use as a routine control test. Following assessment of SLS
534 concentrations over the range 0.25% to 5.0% w/v SLS, the optimum surfactant
535 concentration was identified as 1.0% w/v SLS in water. At this concentration, the rate of
536 tablet dissolution was sufficiently slow to provide the potential for discrimination between
537 tablet variants while still affording complete dissolution within a timescale appropriate for
538 use as a finished product test.

539

540 The paddle speed was selected following evaluation of tablet dissolution at 50, 75 and
541 100 rpm. For all three paddle speeds investigated in 1.0% w/w SLS media, no coning of
542 insoluble tablet excipients was observed; complete dissolution was achieved after 60
543 minutes. From these data, it was concluded that a paddle speed of 50 rpm provided the
544 optimum conditions for use as a routine control test.

545

546 Therefore, the method proposed for ACE tablets uses dissolution apparatus equipped with
547 paddles (speed 50 rpm) and a volume of 900 ml of SLS (1.0% w/v) maintained at a
548 temperature of 37°C, followed by UV spectroscopy at a wavelength of 282 nm.

549

550 The acquired data demonstrated that 1.0% w/v SLS in is the most appropriate dissolution
551 medium for discrimination between tablet batches manufactured by variation of the most
552 relevant product attributes. At a paddle speed of 50 rpm, the 1.0% w/v SLS medium is
553 capable of reproducibly discriminating between tablets manufactured by variation of most
554 relevant input material, processing and formulation variables such as the API particle size,
555 roller pressure and concentration of filler and lubricant. The data also demonstrated that
556 the proposed method is suitable for use as a routine control test.

557 ***3.3. Biopharmaceutics and Pharmacokinetics of ACE***

558

559 Acetripitan has been shown to be stable in gastrointestinal fluid, displays high
560 permeability when investigated using Caco-2 monolayers, and is not susceptible to efflux
561 by P-glycoprotein (P-gp). Solubility of acetripitan is low (0.015 mg/mL) and constant
562 across the physiological pH range due to the lypophilic nature of the molecule. As such,
563 acetripitan can be classified as Class II based on the biopharmaceutics classification
564 system (BCS).

565

566 Acetripitan appears to exhibit linear single-dose pharmacokinetics across the investigated
567 dose range 1 to 40 mg in both healthy volunteers and patients. The apparent mean
568 clearance and volume of distribution were approximately 2.3 L/hr and 80 L, respectively.
569 The mean elimination half-life was 24 hrs, and median T_{max} of 1.3 hrs.

570

571 ***3.4 Prototype Formulation and Process Selection***

572

573 Initial evaluation of physico-chemical properties of the drug substance provided the basis
574 for the selection of roller compaction as the dry manufacturing process. The API is
575 sensitive to heat and as such would not be chemically stable during a drying process
576 required for a wet granulation manufacturing process. Given the target clinical dose of 20
577 mg and in order to obtain an acceptable size tablet, drug concentrations of approximately
578 10% were required in the tablet. The flow properties of acetripitan and excipient blends
579 were not acceptable at a concentration of 10% acetripitan, indicating that acetripitan's
580 physical properties were not suitable for direct compression. The roller compaction
581 process allows for higher drug loads even with acetripitan properties that are not generally
582 acceptable for direct compression. A roller compaction manufacturing process does not

583 expose the acetriptan to excessive heat and results in granules that are acceptable for
584 compression with reliable weight control. A roller compaction process was predicted to
585 achieve the required product attributes with the minimum process complexity and the
586 lowest risk, based on the API liabilities.

587

588 The initial prototype formulation component levels were selected based on prior
589 manufacturing platform knowledge, the properties of acetriptan and acceptable
590 compatibility with acetriptan. The prototype formulation has been utilized in other drug
591 products and resulted in acceptable large scale manufacturing process attributes.
592 Microcrystalline cellulose and lactose monohydrate are among the commonly used
593 diluents for dry granulation formulations, individually and in combination with each
594 other, as they exhibit appropriate flow and compression properties. The initial
595 magnesium stearate level was selected based on knowledge of this formulation and levels
596 required to produce acceptable ejection forces. The disintegrant level was selected to
597 produce short disintegration times that would be expected to produce an acceptable
598 dissolution rate for the immediate release of the poorly soluble drug.

599

600 The initial prototype formulation, which was also used in the pivotal clinical trials,
601 contained the following components:

602

603 Intra-granular:	% w/w Total tablet weight
604 Acetriptan	10%
605 Lactose monohydrate	40.25%
606 Microcrystalline Cellulose	40%
607 Croscarmellose Sodium	3.0%
608 Magnesium Stearate	1.5%

609

610 Extra – granular:	
611 Talc	5.0%
612 Magnesium Stearate	0.25%
613 Total	100.0%

614

615 A risk assessment on formulation composition is shown in **Table 6** below. From this
616 assessment it was concluded that the input variables potentially having the greatest impact
617 on the drug product attributes were the API particle size and concentration, and the levels
618 of the disintegrant and lubricant.

619

620 **Table 6: Formulation Composition Risk Assessment**

621

	Formulation Attributes						
DP CQAs	API level	API particle size	Lactose level	Disintegrant level	MCC particle size	Glidant level	Mg St level
Appearance	Low	Low	Low	Low	Low	Low	High
Identity	Low	Low	Low	Low	Low	Low	Low
Assay	Low	Low	Low	Low	Low	Low	Low
Impurities	Low	Low	Low	Low	Low	Low	Low
Content							
Uniformity	High	High	Low	Low	High	Low	Low
Dissolution	High	High	Low	High	Low	Low	High

622

623

624 The risk assessment also indicated that hardness, dissolution and dose uniformity should
 625 be used as the response variables. It was expected that these would also indicate whether
 626 friability or disintegration would be impacted by composition changes. All formulation
 627 development experiments were conducted at small scale at either 2 kg or 5 kg. The
 628 manufacturing process used to conduct the formulation experiments was a standard roller
 629 compaction process, that included the following manufacturing unit operations:

630

- 631 • Mixing / blending prior to roller compaction
- 632 • Roller compaction / milling
- 633 • Blending / lubrication
- 634 • Tablet compression

635

636 The parameters used for these unit operations were representative of parameters that
 637 would be used as a center point for the process development and all manufacturing
 638 parameters were held constant throughout the formulation development experiments.

639

640 Knowledge from two key formulation development studies is presented in the following
 641 sections. The first study is a formulation component level definition study designed to
 642 establish component levels for the key excipients. The second study was an API particle
 643 size and magnesium stearate interaction study: its design was based on the results of the
 644 first study and was utilized to establish the acceptable magnesium stearate range.

645 3.4.A Formulation Component Level Definition Study

646

647 The formulation component level definition study was designed with the objectives of
 648 establishing preliminary formulation component levels and demonstrating the rationale
 649 for selection of the excipient levels and the target drug concentration. The study was also
 650 utilized to determine if acceptable product attribute responses were obtained over the
 651 range of excipient and drug concentrations studied.

652

653 A central composite response surface design was used with 17 trial runs to study the
 654 impact of three formulation factors on the three key response variables. The factors
 655 studied were as follows:

656

- 657 • Drug Concentration (Load): 5% - 15%
658 • Disintegrant (Croscarmellose Na) Level: 1% - 4% (intragranular)
659 • Lubricant (Magnesium Stearate) Level: 0.75% - 2.25 (intragranular)
660

661 One lot of acetriptan (d₉₀ 20 micron) was employed in the study; therefore, API particle
662 size was constant in all experiments.
663

664 The response variables studied were as follows:
665

- 666 • Tablet hardness at a fixed compression pressure
667 • Dissolution average at a fixed tablet hardness of 12 kP
668 • Tablet weight uniformity (based on correlation to content uniformity)
669

670 Tablets were compressed at three compression pressures and samples were also collected
671 at a target hardness of 12 kP , the compression pressure was adjusted to achieve this
672 hardness. A constant tablet weight of 200 mg was used with the filler amount adjusted to
673 achieve the target weight.
674

675 **Figure 1** contains a plot of the % target tablet weight vs the % label claim for individual
676 tablets tested in this study. For each of the 17 experimental runs, 10 tablets were
677 individually weighed and then tested for drug content. The results compiled in **Figure 1**
678 demonstrate that tablet weight correlates with % label claim and that most of the
679 variability observed in dose uniformity is accounted for by the weight variability. These
680 results indicate that weight uniformity can be used as a predictive surrogate for drug
681 content uniformity, assuming blend uniformity going into compression. Based on this
682 correlation, 100 tablets were individually weighed for each experimental run in order to
683 obtain a more accurate measure of variability for each trial. The tablet weight uniformity
684 data is utilized in the analysis of the data from this study.
685

686 **Figure 1: Plot of % Target Tablet Weight vs % Label Claim for Individual Tablets**
 687 **Tested from Formulation Definition Study**

688

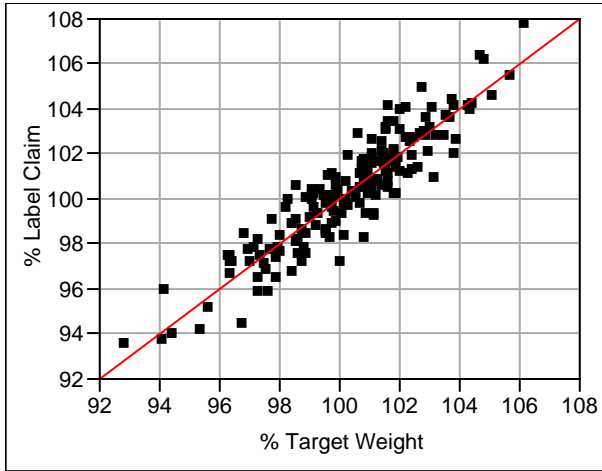

689
 690

691 Note in **Figure 1**: Red line shows theoretical line of perfect agreement between weight
 692 and drug content.

693

694 **Figure 2** presents the interaction profile for the hardness response at a fixed compression
 695 pressure. The interaction profile illustrates the effect of drug load and magnesium stearate
 696 level on tablet hardness. Increasing both variables results in a decrease in hardness with
 697 some interaction between these two variables. The higher drug load shows a larger
 698 decrease in hardness with increasing magnesium stearate level.

699

700 **Figure 2: Interaction profile for Hardness Response at Fixed Compression Pressure.**

701

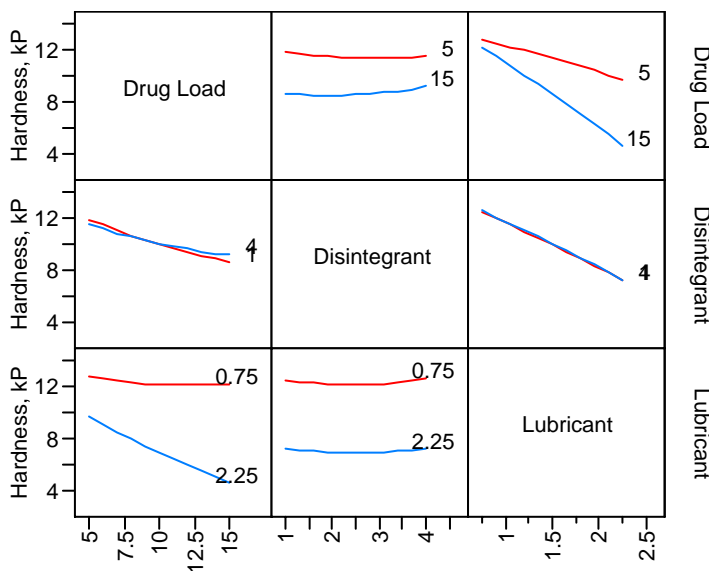

702
 703

704 In order to understand the impact of the formulation variables on dissolution, the
 705 relationship was examined at a fixed tablet hardness of 12 kP. The hardness was fixed at
 706 12 kP because a high hardness would be expected to be the worst case for the dissolution
 707 response. If dissolution were studied at a fixed compression pressure the results could be
 708 confounded by the impact of drug load and magnesium stearate level on the tablet
 709 hardness. As both variables are increased the tablet hardness decreases at a fixed
 710 compression pressure as presented in **Figure 2**. This decrease in hardness would
 711 confound any potential impact the variables have on dissolution because the associated
 712 decrease in hardness usually results in an increase in dissolution.

713

714 **Figure 3** presents the interaction profile for dissolution at a set target tablet hardness of
 715 12kP. This interaction profile demonstrates that the magnesium stearate level has minor
 716 effects on dissolution with the different drug loads. There is a small decrease in
 717 dissolution with increasing magnesium stearate when the disintegrant level is at 1%. This
 718 interaction profile also shows that there is no effect of disintegrant level between 3-4% for
 719 both lubricant levels and drug loads. The dissolution response is 80% or above for all
 720 drug loads, disintegrant and lubricant levels studied, meeting the attribute target criteria of
 721 >75%.

722

723 **Figure 3: Interaction Profile for Dissolution Response at a Set Target Tablet**
 724 **Hardness of 12kP.**

725

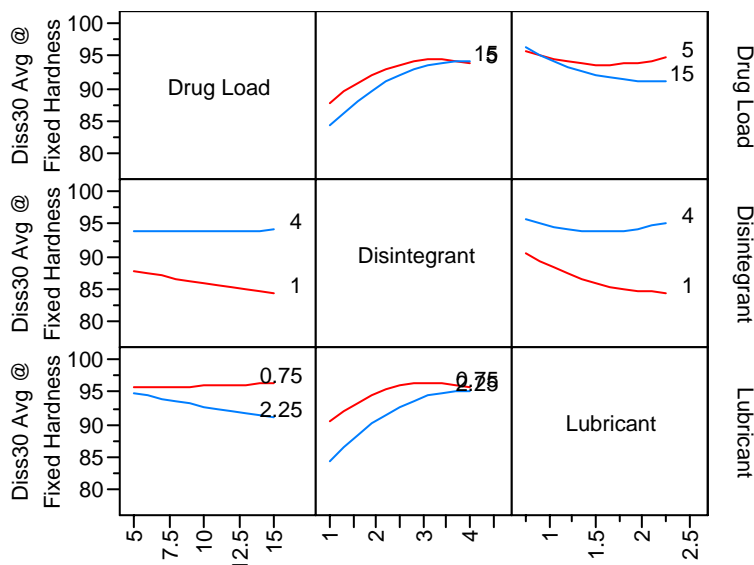

726

727 A contour plot for the 30 minute dissolution response for the 10% drug load at a fixed
 728 tablet hardness is presented in **Figure 4**. This figure illustrates that the predicted average
 729 dissolution is 93% or higher, when the disintegrant level is 3% - 4%, across all levels of
 730 magnesium stearate. The figure also shows a relatively small decrease in dissolution with
 731 increasing lubricant levels at the low disintegrant levels. The predicted average
 732 dissolution response is 85% or above for all regions of the contour plot demonstrating that

733 at the 10% drug load all levels of disintegrant and lubricant will produce tablets meeting
 734 the attribute target criteria of >75%.
 735

736 **Figure 4: Contour plot of Dissolution response for 10% drug load at a set Target**
 737 **Tablet Hardness of 12kP**

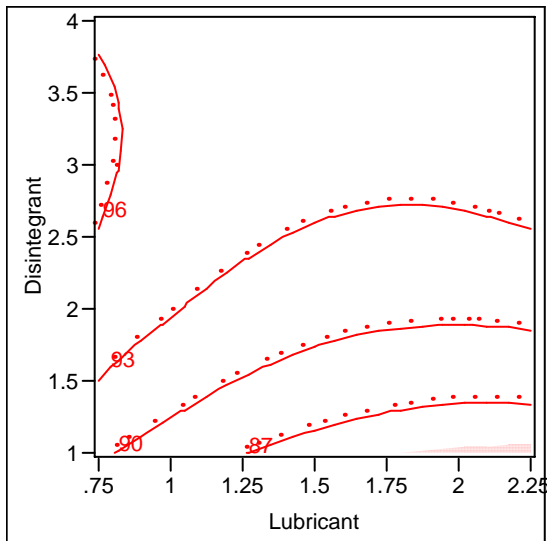

738
 739
 740
 741
 742
 743
 744
 745
 746

Figure 5 presents the interaction profile for the weight %RSD response at a fixed compression pressure. The only trend identified for this response is that increasing drug load increases tablet weight % RSD. This trend indicates that physical properties of the API could impact the weight uniformity, which would be expected. The predicted tablet weight uniformity % RSD responses are 2.6% or lower, which meets the attribute target criteria of < 3.0%.

747 **Figure 5: Interaction profile for Weight %RSD Response at Fixed Compression**
 748 **Pressure.**

749

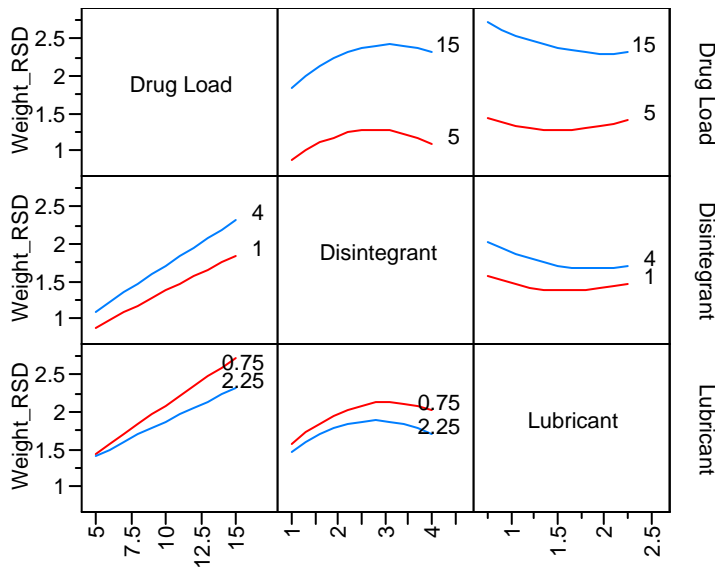

750

751

752 The conclusions from the formulation component level definition study provided the basis
 753 for formulation component level selection. An acceptable predicted response was
 754 demonstrated for weight variation % RSD over the ranges studied. The dissolution
 755 response at a fixed tablet hardness of 12 kP shows only minor effects when the lubricant
 756 level is between 0.75 and 2.25% and the disintegrant level is between 3 – 4%. The
 757 expected commercial dosage is 20 mg such that a 10% drug load would provide a tablet
 758 size that is acceptably small enough for patients to swallow. The response surface for the
 759 10% drug load was robust for dissolution performance and therefore 10% was selected for
 760 use in the formulation. An interaction was observed between the drug load and
 761 magnesium stearate levels with regard to the hardness response. This interaction
 762 indicated the need for further study to determine if API physical properties (particularly
 763 particle size) could impact the hardness response and what level of magnesium stearate
 764 should be used in the commercial formulation.

765

766 3.4.B API Particle Size and Magnesium Stearate Interaction Study

767

768 The API particle size and magnesium stearate interaction study was primarily designed
 769 based on the interaction observed in the formulation component level study between
 770 acetriptan concentration and magnesium stearate level. The objectives of the interaction
 771 study were to: 1) fully characterize how the acetriptan particle size could impact drug
 772 product critical quality attributes; 2) establish the acceptable particle size limits for
 773 acetriptan; and 3) to establish an acceptable magnesium stearate range. The study was
 774 required to fully understand the impact of this interaction for a poorly soluble drug.
 775 Either of these two variables could potentially impact the dissolution rate. Due to the

776 impact on tablet hardness and the potential impact on dissolution, a tighter range of
 777 lubricant was selected for use in this study.

778

779 A response surface design was used to study the impact of two factors at three levels plus
 780 center points, for a total of 11 trial runs. The formulation selected from the component
 781 level definition study with 10% drug load and 3% croscarmellose sodium, was utilized
 782 with a 200 mg total tablet weight. The factors studied were as follows:

783

- 784 • Acetripitan Particle size d_{90} : 10, 25 & 40 microns
- 785 • Lubricant (Magnesium Stearate) Level: 1%, 1.5% & 2% (intragranular)

786

787 The response variables studied were as follows:

788

- 789 • Tablet hardness at a fixed compression pressure
- 790 • Dissolution average at 30 minutes at a set target hardness of 12kP
- 791 • Tablet weight uniformity (based on correlation to content uniformity)

792

793 **Figure 6** presents the interaction profile for the hardness response at a fixed compression
 794 pressure. The interaction profile illustrates the effect of API particle size and magnesium
 795 stearate level on tablet hardness. Increasing both variables results in a decrease in
 796 hardness with an interaction between these two variables. The decrease in hardness with
 797 increasing API particle size is larger at the 2% lubricant level; and the impact of
 798 magnesium stearate level is larger with API particle size of 40 microns. Harder tablets are
 799 produced at lower levels of lubricant or lower API particle size. This figure also
 800 illustrates that an increase in particle size can be compensated for with a decrease in
 801 magnesium stearate level to produce a harder tablet. All hardness responses do meet the
 802 minimum criteria of 5 kP over the ranges studied.

803

804 **Figure 6: Interaction profile for Hardness Response at Fixed Compression Pressure.**

805

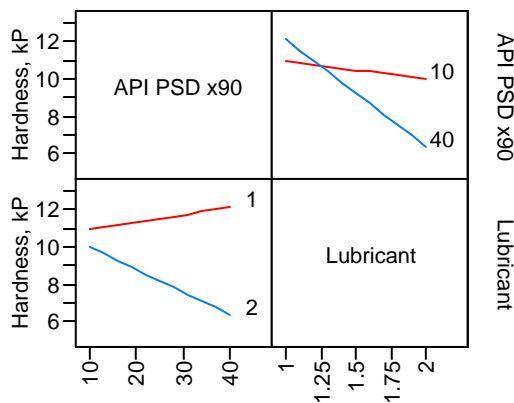

806

807 The interaction profile for the tablet weight %RSD is presented in Figure 7. The
 808 interaction profile illustrates that the magnesium stearate level has no effect on predicted
 809 weight %RSD (although RSD at 1% magnesium stearate is higher than at 2%) and the

810 acetriptan particle size has a relatively small impact on predicted weight %RSD. All
 811 predicted weight % RSD results are below 2.25% over the ranges studied for these two
 812 variables.

813

814 **Figure 7: Interaction profile for Tablet Weight % RSD Response at Fixed**
 815 **Compression Pressure.**

816

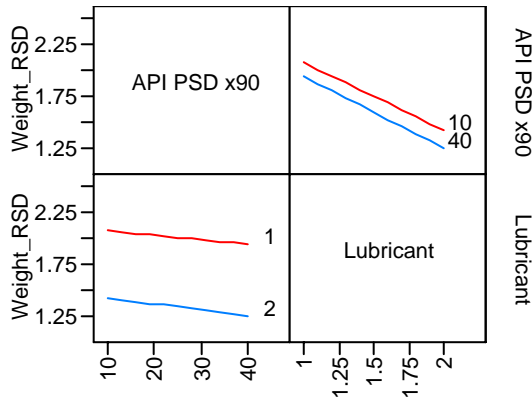

817

818 A contour plot of the dissolution response at a target tablet hardness of 12 kP is presented
 819 in **Figure 8**. As in the previous study, the hardness was fixed at 12 kP because a high
 820 hardness would be expected to be the worst case for the dissolution response. An
 821 interaction between the API particle size and the lubricant level is evident in this figure.
 822 The dissolution response is acceptable over the lubricant range of 1-2% when the particle
 823 size is at the lower end of the range studied. From Figure 8, it can be seen that all
 824 combinations result in dissolutions exceeding the initial target value of 75%. However, a
 825 later in-vivo study showed that a target value for dissolution of 80% was required. The
 826 combination of higher particle size and high lubricant level (upper right hand corner of
 827 Figure 8) results in unacceptable dissolution below the target of NLT 80%. The shaded
 828 area represents the region of unacceptable dissolution, while the large unshaded area
 829 represents acceptable dissolution.

830

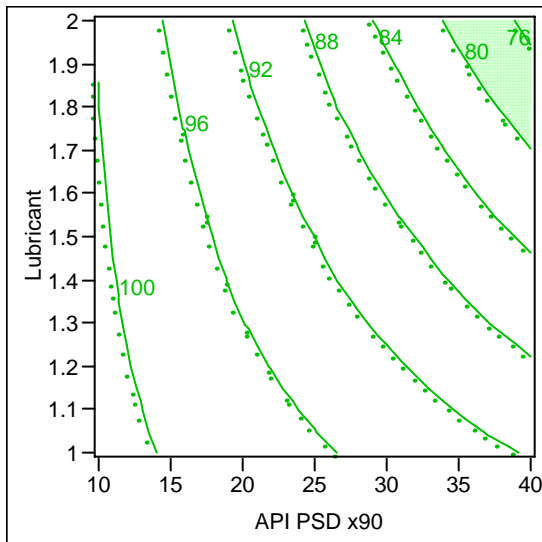
831 **Figure 8: Contour Plot of Dissolution at a Set Target Tablet Hardness of 12kP.**

832

833

834 The conclusions from the API particle size and magnesium stearate interaction study and
 835 the in-vivo study are as follows. Product attributes were acceptable over nearly the full
 836 range of magnesium stearate level and acetriptan particle size. The most significant
 837 effects were observed for dissolution and tablet hardness. There is an interaction between
 838 the acetriptan particle size and the lubricant level. Higher lubricant levels or larger
 839 particle size result in reduced tablet hardness at a fixed compression pressure. At a fixed
 840 tablet hardness of 12 kP, the combination of high lubricant and high acetriptan particle
 841 size results in unacceptable dissolution, which is only a small portion of the design space.
 842 In order to account for the range of acetriptan particle size, the proposed magnesium
 843 stearate range will be linked to the acetriptan particle size to ensure that: 1) acceptable
 844 minimum tablet hardness can be achieved and 2) dissolution meets the criterion of not less
 845 than 80%.

846 **3.5 Summary of Formulation Component Studies**

847

848 The formulation composition is concluded to be:

849

Acetriptan particle size	d ₉₀ 10-35 microns	d ₉₀ 35-40 microns
Acetriptan concentration	10%	10%
Croscarmellose level	3-4%	3-4%
Mg Stearate level	1-2% (intragranular) 0.25% (extragranular)	1-1.75% (intragranular) 0.25% (extragranular)
Microcrystalline cellulose	40% (intragranular)	40% (intragranular)
Lactose monohydrate	38.75 - 40.75%*	39.00 - 40.75%*
Talc	5%	5%

850

851

* Quantity adjusted to compensate for amount of croscarmellose sodium and/or magnesium stearate

852 Formulations containing component levels within the ranges above are predicted to have
853 the following attributes: 1) average dissolution at 30 minutes will be greater than 80%; 2)
854 tablet hardness will be greater than 5 kP, and 3) weight variation will be less than 3.0%
855 RSD (ensuring acceptable drug content uniformity given the low concentration variation).
856 The knowledge presented demonstrates that there is an interaction between the acetriptan
857 particle size and the magnesium stearate level impacting tablet hardness and dissolution.
858 The acetriptan particle size impact can be compensated for, if necessary, by adjusting the
859 magnesium stearate level. Acetriptan with higher particle size decreases dissolution, and
860 this can be compensated for by decreasing the magnesium stearate level. There is no
861 significant impact of magnesium stearate on the critical quality attributes of dose
862 uniformity within the ranges proposed. There is no impact on dissolution over the range
863 of disintegrant levels established (3 – 4%). The impact of varying levels of formulation
864 components on tablet quality was further studied during development of the compression
865 step and in-vivo investigations.

866 **4. Manufacturing Process Development**

867 **4.1 Overview**

868 This section presents the process knowledge and understanding obtained during
869 development of the manufacturing process. The relationship between the input attributes
870 and process parameters and the output attributes, for the unit operations that define the
871 Design Space for the ACE tablet manufacturing process is discussed. This then leads to
872 definition of the control strategy that must be implemented in order to ensure that drug
873 product of appropriate quality is produced.

874
875 The target product profile states that the manufacturing process should be robust and
876 reproducible. The drug product produced must meet the specification for the drug product
877 CQAs of identity, assay, appearance, microbiological, impurities, dissolution and content
878 uniformity and deliver suitable stability in order not to constrain commercialization in
879 worldwide markets.

880 **4.1.A Summary of the selected process**

881 Based on the physico-chemical properties of the API, roller compaction was selected as
882 the most appropriate manufacturing process. The API is sensitive to heat which would
883 preclude wet granulation, due to chemical instability during a drying process. In addition,
884 the API physical properties (flow) precluded direct compression at the concentrations
885 required. Tablet coating was also precluded due to chemical instability during drying. A
886 flow diagram of the manufacturing process for ACE tablets is provided in **Figure 9**.
887 Microcrystalline cellulose, lactose monohydrate, croscarmellose sodium and magnesium
888 stearate are separately weighed and screened and then blended with API. The blend is
889 then roller compacted to produce a ribbon which is milled to give active granules.
890 Extragranular ingredients (magnesium stearate, and talc) are separately weighed and
891 screened and then blended with the granules. The blend is then compressed into tablets.
892

893 **Figure 9: Manufacturing Process Flow for ACE tablets**

894

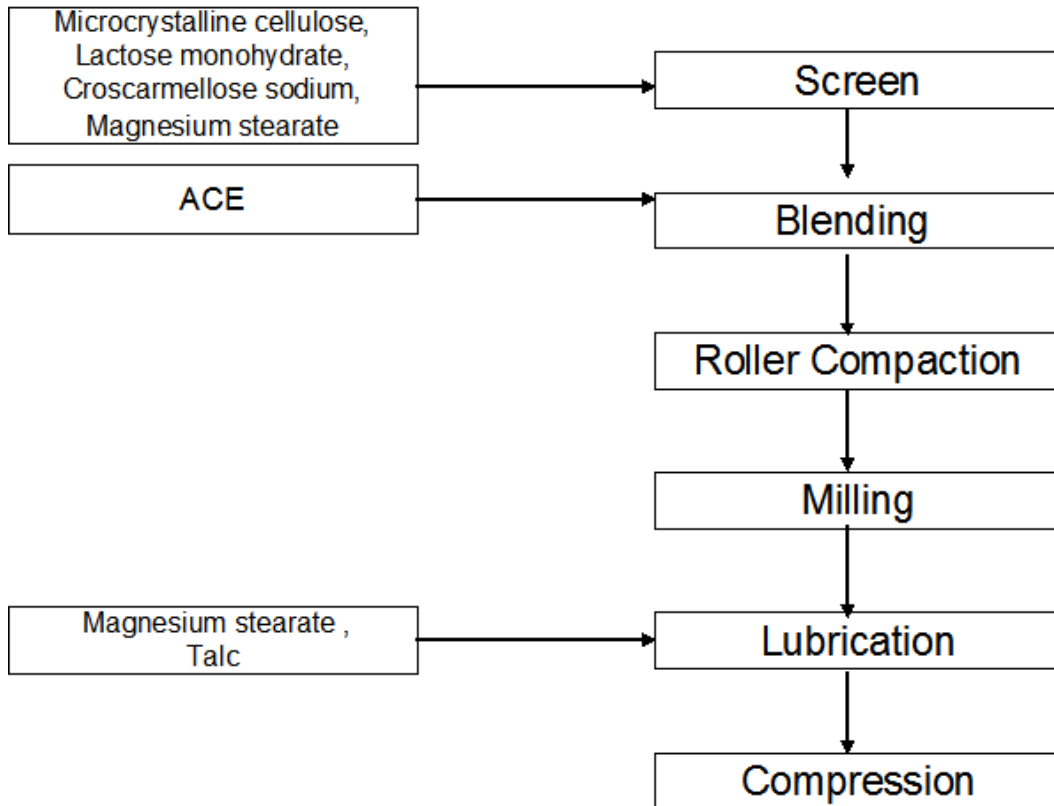

895

896

897 Based on scientific understanding and prior knowledge, a risk assessment of the potential
 898 impact of the unit operations on the drug product CQAs was completed. **Table 7** shows
 899 the result of the risk assessment and identifies the unit operations which require further
 900 investigation to determine the appropriate control strategy.

901

 902 **Table 7: Risk Matrix for Drug Product CQAs for each unit operation**

903

	Unit Operations				
DP CQAs	Blending I	Roller Compaction	Milling	Lubrication	Compression
Appearance	Low	Low	Low	High	High
Identity	Low	Low	Low	Low	Low
Assay	Low	Low	Low	Low	High
Impurities	Low	Low	Low	Low	Low
Content					
Uniformity	High	High	High	Low	High
Dissolution	Low	High	High	High	High

904

905

906 **4.2 Process Optimization – Blending Unit Operation**

907 The manufacturing process uses a blending step followed by roller compaction to obtain
 908 granules for compression. The blend includes approximately 10% active and 90%
 909 diluent, which is mostly lactose monohydrate and microcrystalline cellulose. Despite the
 910 presence of another blending step (lubrication) later in the process train, this processing
 911 step was deemed critical because development studies indicated that material
 912 insufficiently blended at this stage ultimately leads to unacceptable content uniformity of
 913 the finished drug product. Based on the development data, the NIR endpoint parameters
 914 listed in **Table 8** are acceptable

915

916 **Table 8: Process Parameter Ranges for Blending**

917

Process Parameter	Proposed process range
% CV	NMT 5
Moving window size	NLT 10 revolutions

918

919 **4.2.A Method for Determining Blend Homogeneity**

920 NIR was used for determining the endpoint for blending for the majority of the
 921 development work, since it provides real time response and eliminates the challenges and
 922 errors associated with sampling blends. Diffusive blenders of different sizes were fitted
 923 with a NIR sensor. NIR measurements are made once every revolution and the
 924 spectroscopic data is analyzed using a chemometric model. Assessment of the NIR
 925 spectra of the API and excipients indicated that sufficient specificity for the drug can be
 926 obtained, and that NIR is a suitable tool for monitoring this blending process. Using the
 927 chemometric model developed, the moving standard deviation of 6 consecutive spectra is
 928 calculated over the appropriate range of wavelength. The average of the standard
 929 deviations (A_s) is then used to determine the endpoint. The %CV (ratio of standard
 930 deviation to mean) of the A_s is calculated. Once 10 consecutive %CV values are below
 931 5%, the blend is considered homogeneous. The criteria that the %CV stay below 5% for
 932 10 revolutions is to ensure brief excursions below the 5% threshold are not used to
 933 terminate the blending operation.

934 At the laboratory scale, several batches were blended to %CV values of the NIR
 935 predictions of 7% and 12%. These batches were processed through compression and
 936 found to result in elevated tablet content uniformity values of 5.2% and 8.4% RSD,
 937 respectively. Similar batches that were blended to a NIR %CV of 4% were processed
 938 through compression and maintained a tablet RSD less than 2% (**Figure 10**). Based on
 939 these results, the NIR is shown to be capable of accurately assessing the homogeneity of
 940 the blend and can be used to control the endpoint of the blending process. An NIR %CV
 941 value of 5% is predicted to produce tablets with a RSD of approximately 3% (**Figure 10**).

942 **Figure 10: Correlation of Blend NIR CV with Tablet Content Uniformity RSD**

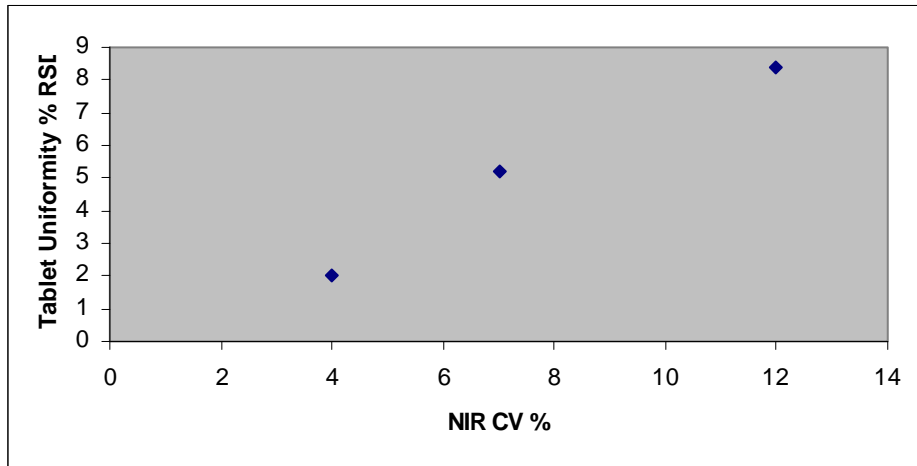

943

944 **4.2.B Critical Parameters Affecting the blend homogeneity**

945 Blending was identified to be a potential risk to content uniformity if appropriate controls
 946 are not in place as indicated in **Table 7**. The blending process was evaluated with a cause
 947 and effect diagram as shown in **Figure 11**.

948 **Figure 11: Cause and Effect Diagram for Blend Uniformity**

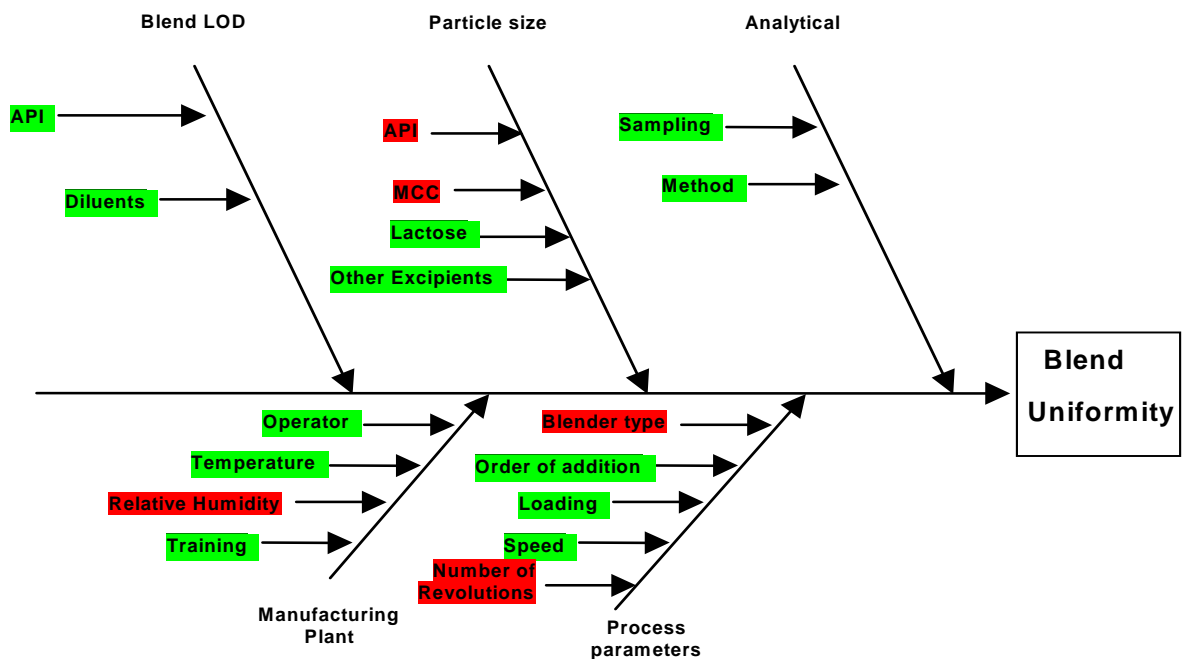

949

950

951 **Low Risk: Based on scientific understanding or prior knowledge** **Potential Higher Risk**

952 The factors potentially affecting blend uniformity were identified. Based on previous
 953 knowledge, it was determined that blend moisture content is affected by the relative
 954 humidity in the manufacturing area and not by the initial water content of the materials.
 955 From prior knowledge, it was known that the particle size of the materials present at
 956 significant levels could play an important role in determining the appropriate blend time
 957 for this type of formulation (API, MCC, lactose). The lactose selected for the formulation
 958 is known to have a consistent particle size distribution, controlled by the material
 959 specification. Therefore the risk of an effect of lactose particle size was low and was not
 960 evaluated further. Based on this cause and effect analysis, a DoE was designed to study
 961 the effects of the most significant factors at the pilot scale: Particle sizes of acetripan and
 962 MCC as well as the environmental humidity. The results of the DoE are discussed below.

963 **Table 9: Risk Matrix Table for Blending Unit Operation**

964

Drug Product Critical Quality Attributes	Blending Unit Operation
Identity	Low
Content Uniformity	High
Assay	Low
Dissolution	Low
Impurities	Low
Appearance	Low

965

966 **Low Risk: Based on scientific understanding or prior knowledge**

967 **Potential Higher Risk**

968

969 The DoE used was a central composite response surface design appropriate for gauging
 970 the relative impact of the listed properties on blend time. A screening design was not
 971 employed because prior experience with this type of formulation gave a reasonable
 972 likelihood that all three factors would be significant to some extent. Ranges of humidity
 973 from 20-70%RH, acetripan particle size (d_{90}) from 10-40 micron and a MCC particle size
 974 (d_{50}) of 30-90 micron were studied. Contour plots for these factors are provided as
 975 **Figure 12**. From these data, an acceptable blend can be produced over the expected
 976 operating range of humidity (20-70 %RH) and particle size (10-40 micron for API and 40-
 977 80 micron for MCC), but the blend time can change dramatically (see **Figure 13**). On the
 978 pilot scale the extreme ends of this range would be from 8 minutes to 36 minutes. The
 979 NIR output was used to determine the blend endpoint in all of these cases, and despite the
 980 wide range of blend times, product of suitable quality could be produced under all
 981 conditions.

982 **Figure 12: Blend Contour plots**

983

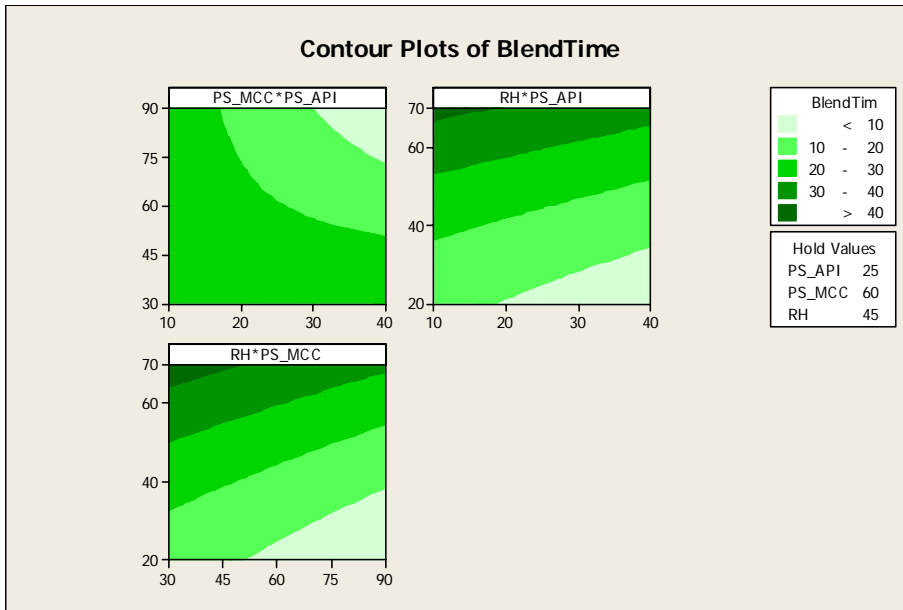

984

985

986 **Figure 13: NIR output of DoE Blending Experiments (Representative Results)**

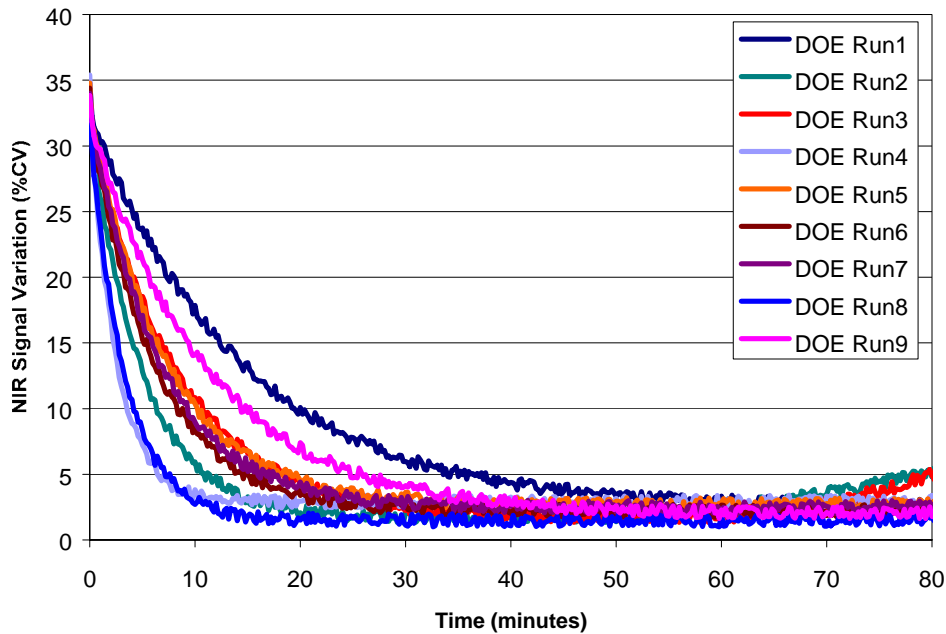

987

988 In two of the DoE experiments with disparate particle sizes for the API and MCC, some
 989 segregation was seen after blending much longer than the minimum blend time
 990 determined by the NIR method. Because of this risk of demixing, blending beyond the

991 point where homogeneity is achieved is to be avoided, and instead, the process should be
 992 terminated when uniformity is first achieved, as determined by the NIR method.

993 **4.2.C Scale-up of the Blending Process**

994 Development of the blending operation was performed at the 1 kg lab scale with a 5 L
 995 capacity diffusive blender operated at 9 rpm and at the 50 kg pilot plant scale with a 200 L
 996 capacity diffusive blender operated at 5 rpm (see **Table 10**). For these scales, the volume
 997 fill ratio was maintained within the range of 40-50% of working volume. At each scale,
 998 the blending was performed until the %CV was less than 5% based on the NIR
 999 measurements. Because traditional scaling rules typically apply to non-cohesive
 1000 materials, they were not applicable for this process because of the cohesive nature of this
 1001 API. This became apparent during development where the blend times at pilot scale were
 1002 longer than expected. In the lab scale batches with 1 kg of material, the NIR endpoint
 1003 criteria were reached at approximately 90 revolutions, occurring at 10 minutes (**Figure**
 1004 **14**). Upon scaling up to the pilot scale (**Table 10**) the NIR-based endpoint was likewise
 1005 reached by 125 revolutions at 25 minutes under similar processing conditions (**Figure**
 1006 **14**). Based on the number of revolutions from lab scale, blending should have been
 1007 achieved in 18 minutes. Although the blend times were different, the end point was
 1008 always achieved, and the 5%CV endpoint as determined by the NIR method results in
 1009 acceptable tablet content uniformity (RSD values ranging from 1.5 to 3.0%). Therefore,
 1010 for commercial production, the on-line NIR will be routinely used to determine the blend
 1011 endpoint for each batch.

1012 **Table 10: Summary of Scale Up Blending Parameters**

1013

Scale	Amount (kg)	Blender Capacity (L)	Blending Speed (rpm)	Volume Fill Ratio
Laboratory	1	5	9	40%
Pilot	50	200	5	50%

1014

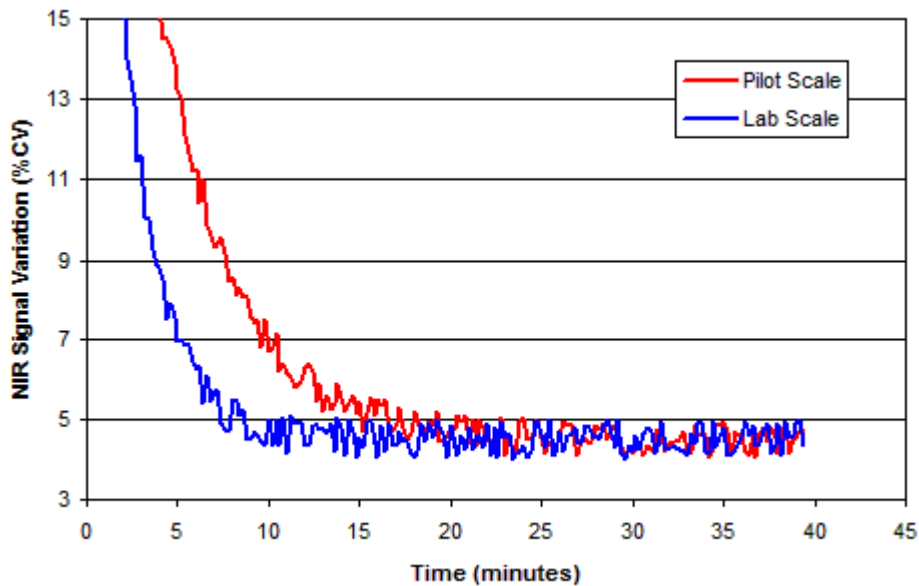
1015 **Figure 14: Blending Control Data**

1016

 1017 **4.2.D Conclusion for Blending**

1018 The blending step discussed here is considered critical to the quality of the product. The
 1019 parameters that can significantly affect the time to the endpoint of the process are: 1)
 1020 environmental humidity and 2) particle size of the API and MCC. **Table 11** exemplifies
 1021 the input attributes that are known to produce blend of acceptable quality.

 1022 **Table 11: Input attributes for Blending Operation**

1023

Input Attributes	Range
Humidity	20-70% RH
API (d ₉₀)	10-40 micron
MCC (d ₅₀)	30 - 90 micron
Equipment	Any diffusive blender
Lactose (d ₅₀)	70 – 100 micron
Scale	Any

1024

1025 In all cases, acceptable blending is achieved although blend times may vary. It is
 1026 proposed that NIR be used for routine determination of the endpoint of the blending

1027 process. Blending will terminate as soon as uniformity is achieved. Because NIR
 1028 monitoring of the blend ensures that adequate mixing is performed, it obviates the need to
 1029 specify any of the process parameters such as rotation speed, time, scale, excipient
 1030 sources or equipment (provided a diffusive blender is employed).

1031 A risk matrix table (**Table 12**) for the blending operation demonstrates that the identified
 1032 risk to the quality attributes has been mitigated by: 1) control of acetriptyan, 2) lactose and
 1033 MCC particle size, 3) environmental humidity and 4) online NIR control.

1034 **Table 12: Risk Matrix Table for Blending Unit Operation after Controls**

Critical Quality Attributes	Blending Unit Operation
Identity	Prior Knowledge
Content Uniformity	NIR End Point Control
Assay	Prior Knowledge
Dissolution	Prior Knowledge
Impurities	Prior Knowledge
Appearance	Prior Knowledge

1035

1036 **Low Risk**

1037 **High Risk**

1038

1039 **4.3 Process Optimization – Roller Compaction Unit Operation**

1040 **4.3.A Introduction**

1041 The purpose of the roller compaction and milling stages is to produce granulated product
 1042 that is suitable for subsequent blending and compression. The initial blend is transferred
 1043 to the roller compactor where a screw-feeder drives it between two rollers, which compact
 1044 the material. The compacted ribbon is then broken up and passes through a rotating
 1045 impellor screen mill.

1046

1047 A process map for roller compaction and milling is presented in **Figure 15**. This was
 1048 used to map the inputs, process parameters, product measures and outputs for both roller
 1049 compaction and milling.

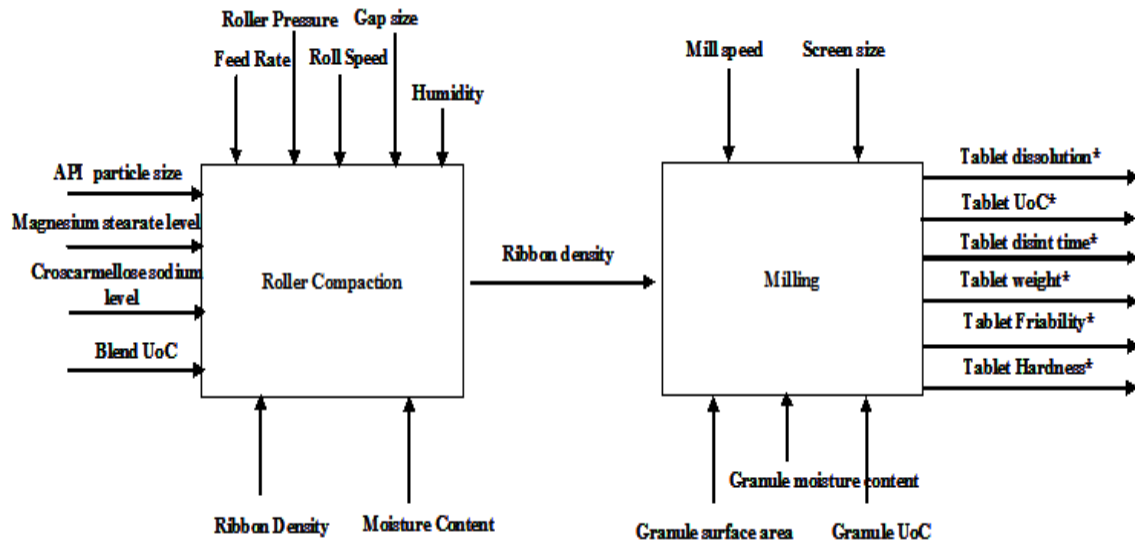
1050 **Figure 15: Process Map for Roller Compaction and Milling**

1051

1052 * Final product attributes, not direct outputs from milling

1053

1054 This process map and prior scientific knowledge were used to perform the initial Quality
 1055 Risk Assessment (QRA-1) from which factors that might affect product quality were
 1056 proposed and then risk-scored. Subsequently, experimental studies were designed and
 1057 executed to develop new scientific knowledge and allow further refinement of the risk
 1058 assessment (QRA-2), thus enabling risk reduction through increased understanding and
 1059 establishment of appropriate controls.

1060 4.3.B Failure Modes, Effects and Criticality Analysis (FMECA) approach to 1061 Roller Compaction

1062

1063 A Failure Modes, Effects and Criticality Analysis (FMECA) approach was used to
 1064 identify the most relevant raw materials attributes and process parameters in the roller
 1065 compaction and milling steps that have the potential to impact product quality, and to
 1066 allow each failure mode to be scored and ranked in terms of risk.

1067

1068 Each variable (potential failure mode) was scored in terms of probability, severity and
 1069 detectability. Once defined, these scores were multiplied together to produce a “Risk
 1070 Priority Number” (RPN), which represents the overall magnitude of the risk.

1071 4.3.C Initial Quality Risk Assessment (QRA-1) for the roller compaction 1072 and milling stages

1073 The starting point for the initial quality risk assessment (QRA-1) was the process map for
 1074 the roller compaction and milling stages, see **Figure 15**. The process map was used to
 1075 identify input material attributes and process parameters that had the potential to have an
 1076 impact on product quality.

1077 Based on prior knowledge and the outcome of development studies to investigate the
 1078 preceding unit operations the following conclusions were reached:

- 1079
- 1080 1. The only formulation variables to consider from the formulation component level
 1081 ranges are:
- 1082 a. Acetripitan particle size (d_{90} =10 to 40 μm)
- 1083 b. Croscarmellose sodium (CCS) level (3 to 4% w/w)
- 1084 c. Magnesium stearate level (1.25 to 2.25% w/w)
- 1085 2. Initial blend uniformity of content will be routinely assured. Endpoint will be
 1086 continuously verified using in line NIR (% CV < 5%). Furthermore, a diffusive
 1087 blender will always be used. Therefore it was considered that uniformity of
 1088 content would be acceptable at the point of roller compaction.

1089 The outcome of the initial quality risk assessment (QRA-1) is summarized in **Figure 16**.
 1090

1091 **Figure 16: Initial Quality Risk Assessment (QRA-1) for the Roller Compaction and**
 1092 **Milling stages**

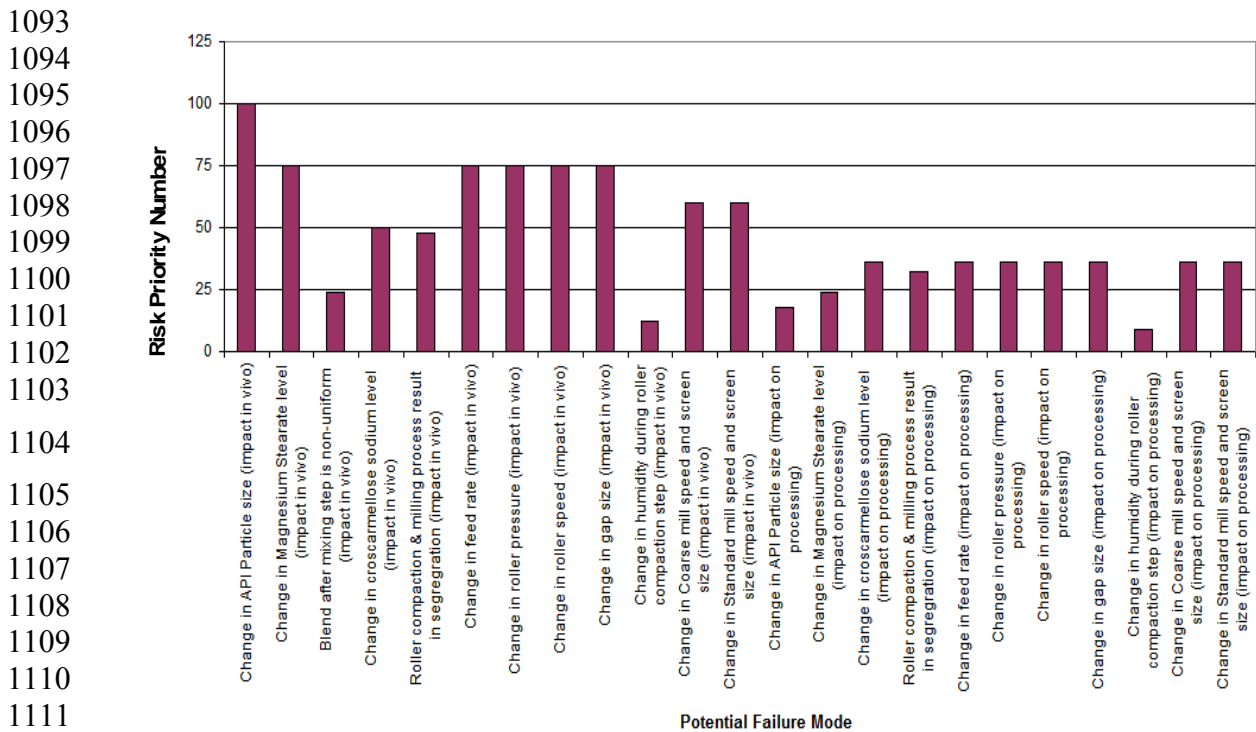

1113 From this risk assessment, it can be seen that the failure effects fell into two high-level
 1114 categories; those that could have an impact on *in vivo* performance, and those that could
 1115 have an impact on processing (e.g. granule flow) and product physical quality.

1116 Furthermore, those that could affect *in vivo* performance have generally been scored
1117 higher than those that could affect processing or product physical quality. This difference
1118 in scoring is linked to both the detectability and severity associated with each failure
1119 effect. For those failure effects that could have an impact on processing and product
1120 physical quality, detectability was high, occurring either: 1) during the unit operation, 2)
1121 during a subsequent unit operation or in some cases, 3) at finished product testing. As a
1122 consequence, the severity score could often be limited by rejection of the affected batch.
1123 However for those failure effects that could have an impact on *in vivo* performance,
1124 higher severity scores were given.

1125

1126 Due to the controls introduced at the blending stage, the risk of the input blended material
1127 having a non-uniform distribution was low. Based on prior knowledge, it was unlikely
1128 that the roller compaction and milling stages would cause segregation. Testing to confirm
1129 this would form part of experimental studies to increase product understanding of the
1130 roller compaction and milling stages.

1131

1132 Changes to humidity leading to variability in product moisture content were considered to
1133 be low risk because previous studies to assess the kinetic and equilibrium moisture
1134 content of the drug substance, excipients and formulation blends (which cover the
1135 extremes of the formulation component levels) demonstrated that there was no significant
1136 impact on the product output attributes across relative humidities of 20 to 70% RH. Based
1137 on this, relative humidity and product moisture content would not be investigated further.

1138

1139 The initial quality risk assessment (QRA-1) has allowed the highest risks to be identified.
1140 The highest risks have been identified as those associated with changes to the input raw
1141 materials (changes in API particle size, change to magnesium stearate level and change to
1142 CCS level) and process parameters for both the roller compaction and milling steps.
1143 Consequently an experimental approach was defined that allowed these risks to be
1144 investigated further, to determine if any controls would need to be applied.

1145 **4.3.D Process Development Work**

1146 Investigation of the formulation and process variables identified in QRA-1 was
1147 undertaken in two stages. Firstly, the effects of these six factors were investigated in a
1148 two-level, factorial, screening design, which consisted of 32 batches. After identification
1149 of the most relevant cause and effect relationships, the identified factors were further
1150 investigated using a response surface model design to elucidate the opportunity for control
1151 if required. These investigations were performed at a 1kg scale. This is described in
1152 more detail in the following sections.

1153 **4.3.D.1 Roller Compaction and Milling: DoE-1**

1154 ***Factors Investigated***

1155 The following six factors were investigated to better understand their effects, including
1156 interactions, on intermediate and final product attributes:

- 1157 • Acetripitan particle size (10 and 40 μm)
- 1158 • Magnesium Stearate level (1.25 and 2.25% w/w)
- 1159 • Croscarmellose Sodium level (3 and 4% w/w)
- 1160 • Roller pressure (50 and 150 bar)
- 1161 • Mill screen size (0.039 and 0.062 inches)
- 1162 • Mill speed (600 and 1200 rpm)
- 1163

1164 Acetripitan particle size and magnesium stearate level were known to interact from the
1165 formulation study. The purpose of this investigation was to evaluate the impact of roller
1166 compaction on the interaction between acetripitan particle size and magnesium stearate
1167 level. At the roller compaction stage, only roller pressure was investigated because prior
1168 knowledge has shown that varying the respective roller compaction process variables
1169 leads to the same effect, i.e. changes in ribbon density, meaning investigating the other
1170 factors adds no value. Furthermore, roller pressure is the process variable likely to have
1171 the greatest effect on ribbon density and is also straightforward to control. As ribbon
1172 density is the product attribute at this stage that is most likely to impact downstream
1173 processing and product performance, this was considered an appropriate approach.

1174
1175 For the purposes of DoE-1, the parameters of the subsequent unit operations (e.g.
1176 blending and compression) were fixed in order to enable correlation of any differences
1177 observed in drug product quality with variation introduced at the roller compaction and
1178 milling stages. For example, tablets with a hardness of 12 Kp were used in all
1179 evaluations. Previous work had suggested that tablet hardness has an impact on tablet
1180 dissolution and therefore worst-case interactions between variables at the roller
1181 compaction, milling and compression stages could be investigated.

1182 **Responses**

1183 Based on previous experience with similar formulations, the following responses (which
1184 include both intermediate and final product attributes) were measured to assess the impact
1185 of varying input materials and process parameters during the roller compaction and
1186 milling steps:

1187 ***In-process Product Attributes***

- 1188 • Ribbon density
- 1189 • Granule surface area
- 1190 • Granule uniformity of content

1191 ***Final Product Attributes***

- 1192 • Tablet weight
- 1193 • Tablet hardness
- 1194 • Tablet friability
- 1195 • Tablet disintegration time

- 1196
- Tablet dissolution
- 1197
- Tablet uniformity of content
- 1198

1199 **DoE- 1: Results and Discussion**

1200 These data were analyzed and significant cause and effect relationships identified. These
 1201 will be presented in two stages; 1) those factors shown to impact on in-process product
 1202 attributes, and 2) those factors shown to impact on final product attributes.
 1203

1204 **Significant Factors for In-process Product Attributes**

1205 The only significant factor affecting ribbon density was roller pressure. This is shown by
 1206 the half normal plot and ANOVA data provided in **Figure 17**.
 1207

1208 **Figure 17: Half-normal Plot and ANOVA for Effects on Ribbon Density**

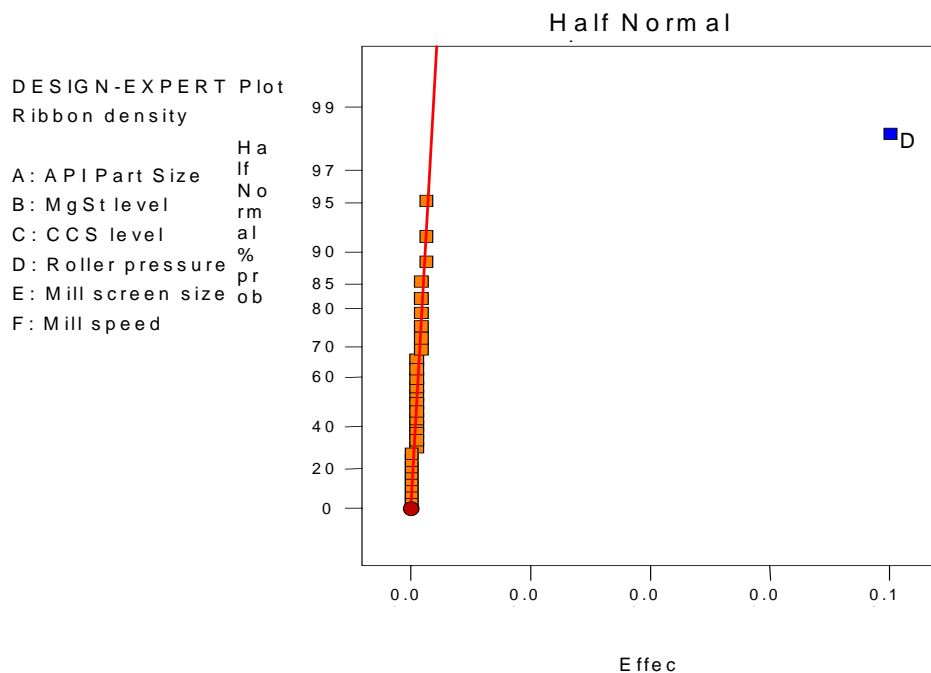

1209

Factor	Coefficient Estimate	DF	Standard Error	t for H ₀ Coeff=0	Prob > t	VIF
Intercept	0.74	1	9.057E-04			
D-Roller pressur	0.059	1	9.057E-04	65.56	< 0.0001	1.00

1210
1211

1212 This figure shows the dominating effect of roller pressure on ribbon density with little or
 1213 no effect of the other factors investigated. The relationship between roller pressure and
 1214 ribbon density is presented in **Figure 18**. Some further work was required to investigate

1215 more central data points and to determine if any curvature existed in this relationship.
 1216 This was part of a second design of experiments (DoE-2).

1217 **Figure 18: Relationship between Roller Pressure and Ribbon Density**

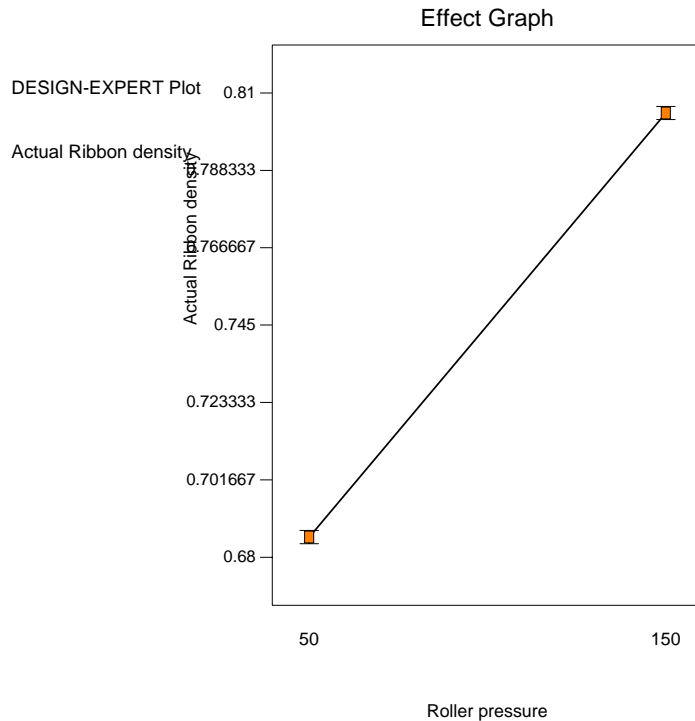

1218
 1219 Two significant factors were shown to affect granule surface area (GSA) and these were
 1220 also found to interact to a minor extent. These factors were mill screen size and mill
 1221 speed. The half normal probability plot and ANOVA in **Figure 19** shows that mill screen
 1222 size had, by far, the most significant impact on GSA with a minor effect imparted by mill
 1223 speed and the interaction between screen size and mill speed.

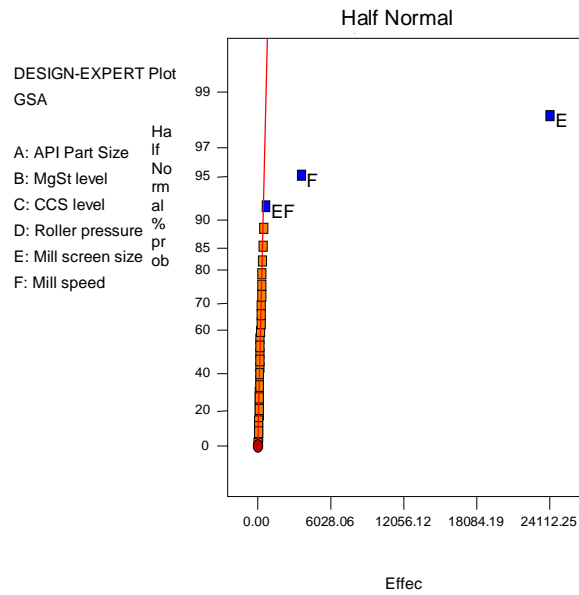
1224 **Figure 19: Half-normal Plot and ANOVA for Effects on GSA**

1225

Factor	Coefficient		Standard		t for H ₀		VIF
	Estimate	DF	Error	Coeff=0	Prob > t		
Intercept	26765.38	1	110.04				
E-Mill screen siz	-12056.12	1	110.04	-109.57	< 0.0001	1.00	
F-Mill speed	1789.94	1	110.04	16.27	< 0.0001	1.00	
EF	328.69	1	110.04	2.99	0.0058	1.00	

1226

1227

1228

 1229 The relative effects of mill screen size and mill speed on GSA are more clearly illustrated
 1230 in **Figure 20**. This further highlights the dominating effect of screen size.

1231 **Figure 20: The Effects of Mill Screen Size and Mill Speed (600 or 1200 rpm) on GSA**

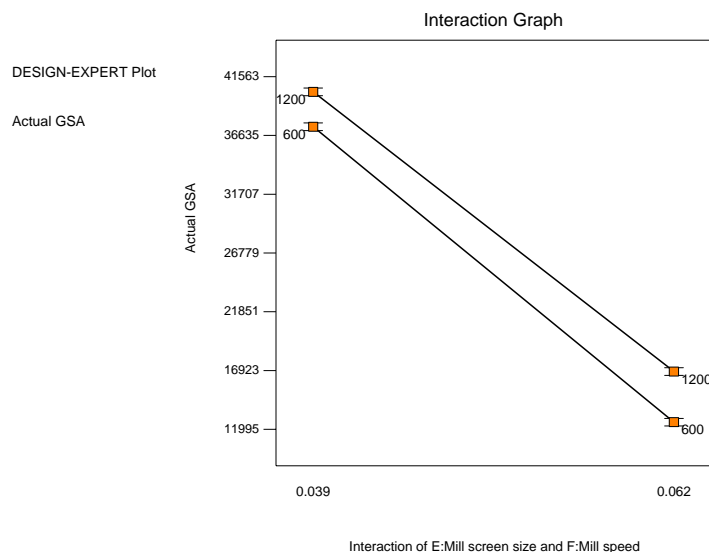

1232

1233 It was also demonstrated that varying the formulation and process factors had no impact
 1234 on granule uniformity of content. Furthermore, assay of the granule sieve fractions
 1235 showed that the API is distributed evenly from the fine to coarse fraction further reducing
 1236 the risk of downstream product segregation leading to unacceptable tablet uniformity of
 1237 content.

1238

1239 **Significant Factors for Final Product Attributes**

1240 Hardness and dissolution were the only product attributes affected by the factors
 1241 investigated. No significant cause and effect relationships were identified for the other
 1242 final product attributes, i.e., tablet weight, friability and uniformity of content.
 1243 Three significant factors were identified for dissolution including a number of
 1244 interactions. These were API particle size, magnesium stearate level and roller pressure.
 1245 The half normal probability plot and ANOVA in **Figure 21** show that, in terms of single
 1246 factor effects, acetriptan particle size had the most significant effect. This was followed
 1247 by roller pressure and then the magnesium stearate level. Varying levels of
 1248 croscarmellose sodium were shown to have no significant effect.

1249

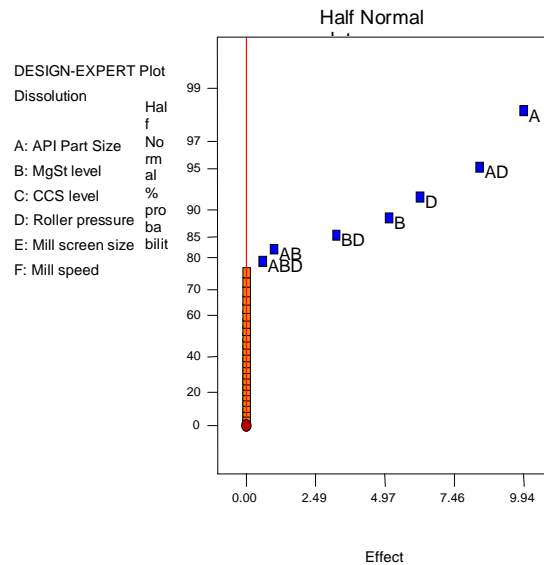
1250 **Figure 21: Half-normal plot and ANOVA for effects on tablet dissolution**

1251

Factor	Coefficient Estimate	DF	Standard Error	t for H ₀ Coeff=0	Prob > t	VIF
Intercept	86.99	1	0.000			
A-API Part Size	-4.97	1	0.000	-7978.72	< 0.0001	1.00
B-MgSt level	-2.56	1	0.000	-7978.72	< 0.0001	1.00
D-Roller pressur	-3.11	1	0.000	-7978.72	< 0.0001	1.00
AB	-0.50	1	0.000	-7978.72	< 0.0001	1.00
AD	4.18	1	0.000	7978.72	< 0.0001	1.00
BD	-1.61	1	0.000	-7978.72	< 0.0001	1.00
ABD	-0.29	1	0.000	-7978.72	< 0.0001	1.00

 1252
1253

 1254 **4.3.E DoE-2: Roller compaction response surface**

 1255 The three factors found to have a significant effect on tablet dissolution by the screening
 1256 DoE (API particle size, roller pressure and magnesium stearate level) were further
 1257 investigated in a response surface DoE (12 experiments) in an attempt to better
 1258 understand the inter-relationships between these factors. This would allow the potential
 1259 for appropriate control of dissolution performance.

1260 This second DoE used the following ranges:

1261

 1262 Acetripitan particle size d_{90} 10-40 micron
 1263 Magnesium Stearate level 1-2% intragranular, 0.25% extragranular
 1264 Roller pressure 50 –150bar
 1265

 1266 Contour plots for API particle size and roller pressure versus dissolution rate (at different
 1267 magnesium stearate levels) are included in **Figure 22**, **Figure 23**, and **Figure 24**. The
 1268 results confirmed that all parameters investigated had an impact on dissolution rate, and

1269 that particle size had the most significant effect followed by roller pressure and then
 1270 magnesium stearate. The contour plots also demonstrate the interaction between the
 1271 parameters investigated. For example, if a minimum of 90% dissolution at 30 minutes
 1272 was required then this could be achieved by controlling API particle size alone; or through
 1273 a combination of particle size, roller pressure and/or magnesium stearate level. Therefore
 1274 by application of the understanding gained from DoE-2, it would be possible to assure
 1275 dissolution performance by control of input material attributes and process parameters.
 1276

1277 **Figure 22: Contour plot for API particle size and roller pressure versus tablet**
 1278 **dissolution (% at 30 mins) with a 1% magnesium stearate level**

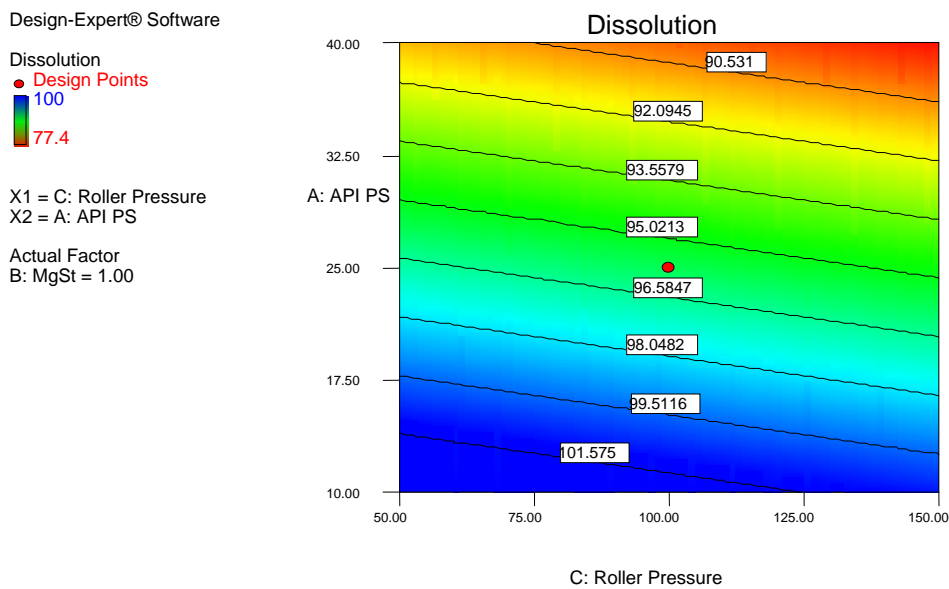

1279

1280

1281 **Figure 23:** Contour plot for API particle size and roller pressure versus tablet dissolution
 1282 (% at 30 min) with a 1.5% magnesium stearate level

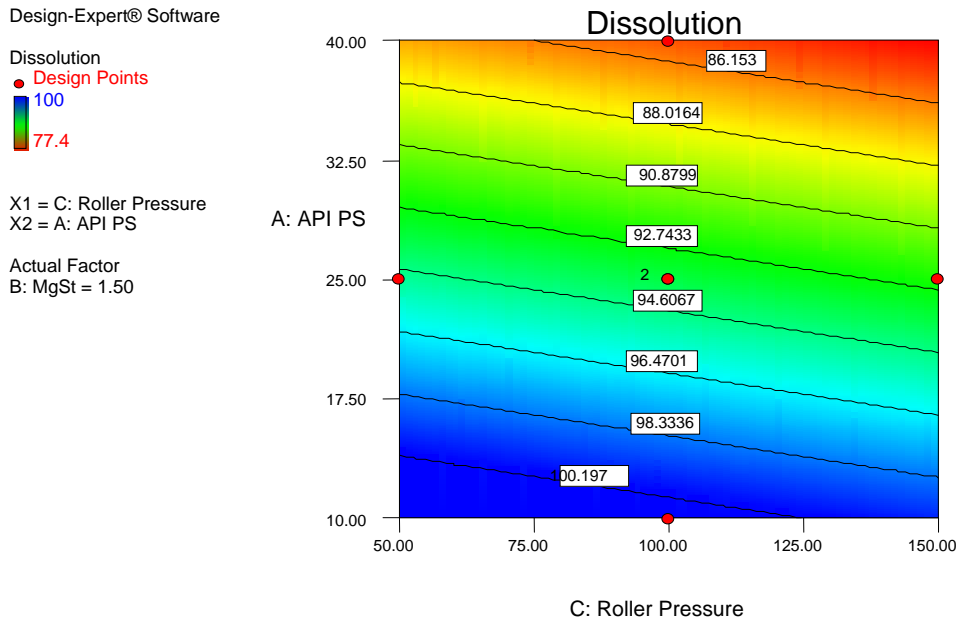

1283

1284 **Figure 24:** Contour plot for API particle size and roller pressure versus tablet
 1285 dissolution (% at 30 min) with a 2% magnesium stearate level

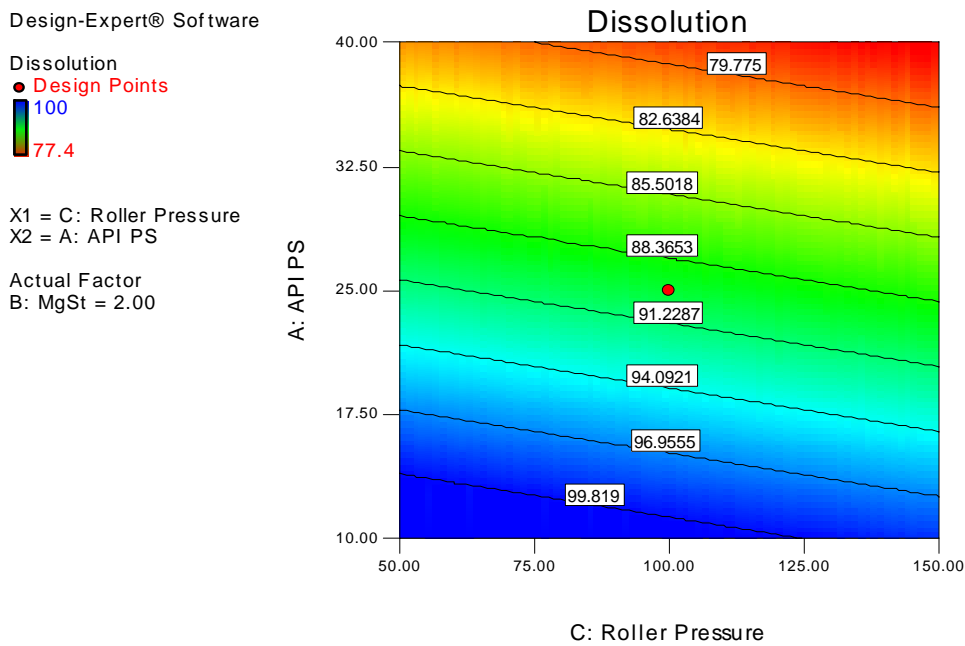

1286

1287 In addition this work confirmed a linear relationship between roller pressure and ribbon
 1288 density i.e. no curvature exists (see **Figure 25**). Based on this linear relationship and the
 1289 observed relationship between roller pressure and tablet dissolution rate it can be
 1290 concluded that a relationship between ribbon density and tablet dissolution rate also
 1291 exists. The establishment of this relationship is significant, as it enables an intermediate
 1292 material attribute (ribbon density) to be used as a control to assure dissolution
 1293 performance.

1294 **Figure 25: Confirmed Linear Relationship between Roller Pressure and Ribbon**
 1295 **Density**

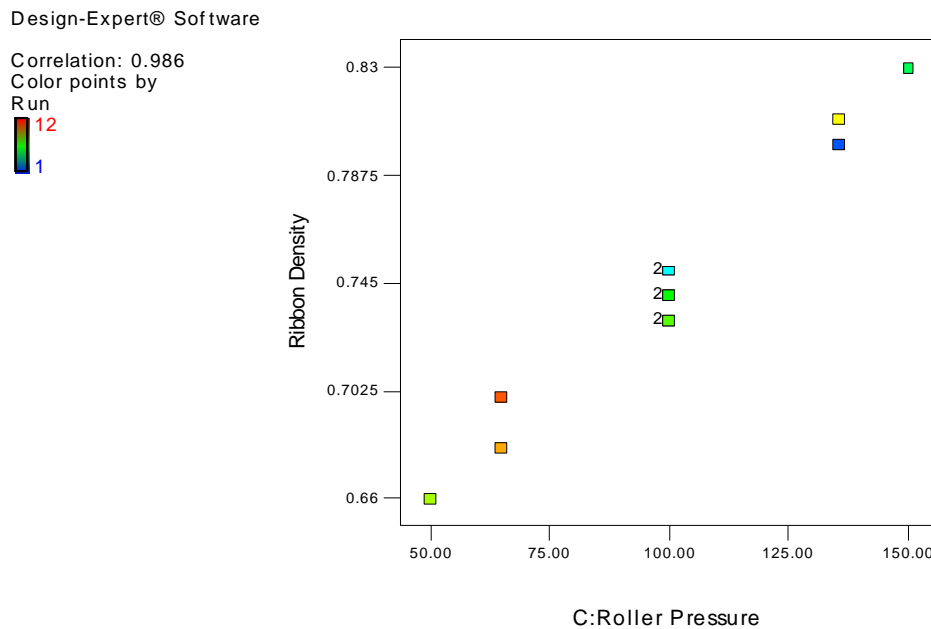

1296

1297 **Impact of Scale**

1298 As shown above, the roller pressure (compaction force) and material mechanical (yield)
 1299 properties impact the results of roller compaction (i.e., ribbon density). Johansen (J. App.
 1300 Mech. p.842, Dec. 1965), identified several dimensionless groups for roller compaction
 1301 and these are given below in **Figure 26**.
 1302

1303 **Figure 26: Description of Parameters associated with Roller Compactor**

1304

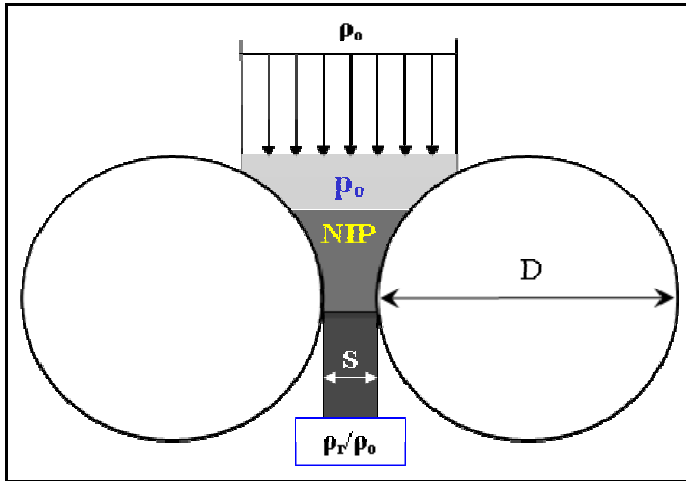
 Ω = roll speed [1/T]

 D = roll diameter [L]

 s = roll gap width [L]

 p_0 = feed pressure [$F/L^2 = M/LT^2$]

 E = Young's modulus [$F/L^2 = M/LT^2$]

 σ_y = yield stress [$F/L^2 = M/LT^2$]

 ν = Poisson's ratio [-]

 ϵ_0 = initial porosity [-]

 μ_{pr} = friction between powder/roll [-]

 μ_{pp} = internal powder friction [-]

 ρ_0 = initial bulk density [M/L^3]

 ρ_r = ribbon bulk density [M/L^3]

1305

1306

 1307 where the square brackets [...] indicate the dimensions of a parameter, T refers to time, L
 1308 is length, M is mass, and F is force ($= ML/T^2$).

1309

1310 The dimensional relation between the ribbon bulk density and the other parameters may
 1311 be written as:

1312
$$\rho_r = fcn_1(D, \Omega, s, p_0, E, \sigma_y, \nu, \epsilon_0, \rho_0, \mu_{pr}, \mu_{pp}) \quad (1)$$

1313

1314 In dimensionless form, Eqn. (1) may be written as:

1315
$$\frac{\rho_r}{\rho_0} = fcn_2\left(\frac{s}{D}, \frac{p_0}{\rho_0 \Omega^2 D^2}, \frac{E}{p_0}, \frac{\sigma_y}{E}, \nu, \epsilon_0, \mu_{pr}, \mu_{pp}\right) \quad (2)$$

1316

 1317 The dimensionless parameters in Eqn. (2) serve to establish truly scale and equipment
 1318 independent metrics. Using the *relative density* of the ribbon (ρ_r/ρ_0) as the response, the
 1319 range of s/D , $p_0/(\rho_0 \Omega^2 D^2)$, and E/p_0 were selected to give an acceptable ribbon density.

1320

 1321 Such a scale independent relationship is illustrated in parallel coordinates as shown below
 1322 in **Figure 27**.

1323

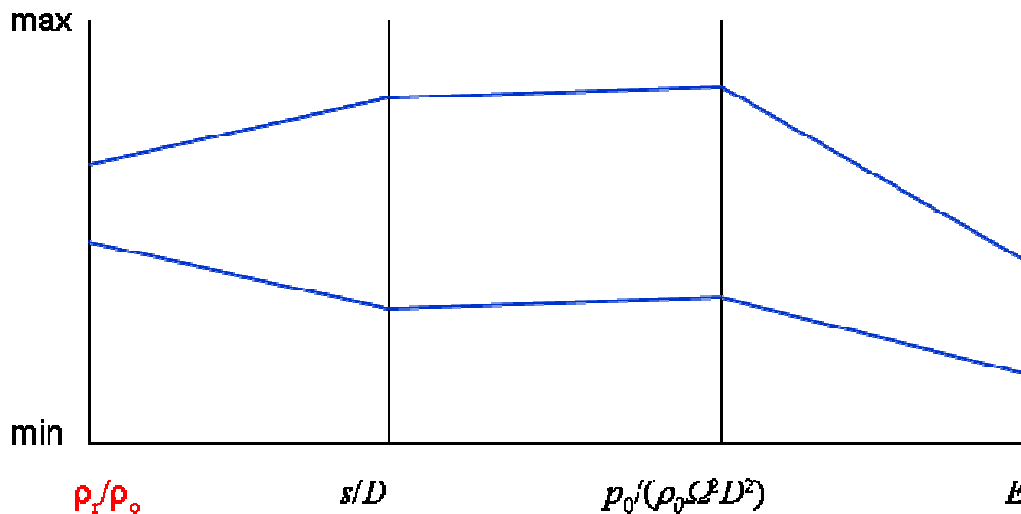
1324 **Figure 27: Scale independent Relationship Illustration**

1325
1326 This process understanding establishes the independence of site, scale, and equipment.

1327 4.3.F Roller Compaction and Milling Conclusions

1328 The conclusions from this work were:

- 1329 1. All dissolution values were in the range 75-100% at 30 minutes. However, a later
1330 in-vivo study showed that a target value for dissolution of 80% was required.
- 1331 2. Dissolution was only affected by acetriptan particle size, magnesium stearate level
1332 & roller pressure. This included a number of interaction terms.
- 1333 3. Ribbon density was directly affected by roller pressure. This is a linear
1334 relationship and is independent of the other factors that were investigated. A
1335 relationship between ribbon density and tablet dissolution rate was also concluded
- 1336 4. All ribbon densities were in the range 0.68 – 0.81.
- 1337 5. Dissolution can be controlled by placing boundaries on acetriptan particle size,
1338 ribbon density and magnesium stearate level.
- 1339 6. No significant cause and effect relationships were identified between the factors
1340 investigated and the remaining final product attributes, i.e. tablet weight, hardness,
1341 friability, and uniformity of content.
- 1342 7. Granule Surface Area (GSA) was only affected by mill screen size and mill speed.
1343 Screen size was shown to be the dominating factor with mill speed imparting a
1344 minor effect. However, there was no impact of the milling parameters (and
1345 consequently GSA) on final product attributes within the ranges studied.
- 1346 8. Varying the input factors had no impact on granule uniformity of content.

1347 9. Assay of the granule sieve fractions showed that the acetriptan is distributed
1348 evenly from the fine to coarse fraction.

1349 The knowledge gained from the process development work is summarized in a cause and
1350 effect diagram, presented in **Figure 28**.
1351

1352 **Figure 28: Roller Compaction: Summary of Cause and Effect Relationships**
1353 **identified from Process Development Studies**

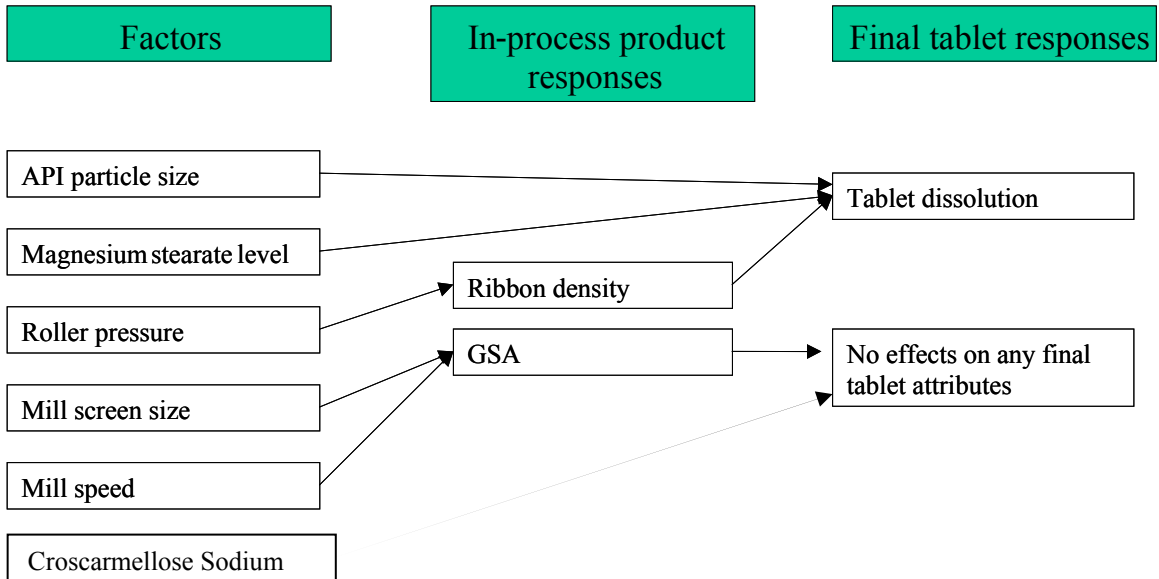

1354
1355
1356 Ribbon density is proposed to be measured in-line by NIR as part of the control strategy.
1357 This is described further below.

1358
1359 The intent of the control strategy for roller compaction is to maintain the ribbon density
1360 within the required range to ensure drug product of appropriate product quality can be
1361 produced. To maintain a ribbon density of 0.68 to 0.81 during routine operation, a real
1362 time NIR in-process control will be employed. This will be based on two elements:

- 1363 1. NIR will be used as a real time surrogate measure for ribbon density to detect any
1364 variability
- 1365 2. The cause and effect understanding, generated during process development, will
1366 be used to react to any variability and correct it.

1367 This is represented schematically in **Figure 29**.
1368

1369 **Figure 29: NIR in-process control feedback loop**

1370

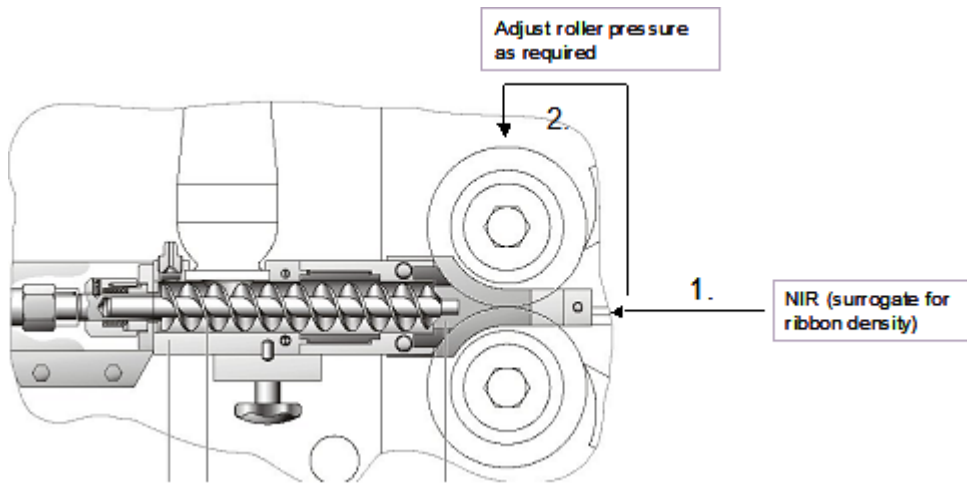

1371

1372

1373 The surrogate NIR measure for ribbon density was established through extensive
1374 calibration work to ensure that a robust in-process control model was established.

1375

1376 The milling studies showed acceptable process performance and generated GSA between
1377 12,000 to 41,000 cm²/100g. No routine control strategy will be employed at the milling
1378 stage; however, some controls will be applied as part of change management. For the
1379 initial process, mill screen size and speed will be selected to ensure that GSA will remain
1380 within the proven ranges. If a change to the mill is made e.g. scale-up or down, then the
1381 impact on granule surface area will be assessed across the pre-defined ribbon density
1382 range. Changes to the mill screen or impeller speed may be required at this stage to
1383 ensure that granules manufactured during future routine operation fall within the proven
1384 GSA ranges across the defined ribbon density.

1385 **4.3 G Second Risk Assessment for Compaction and Milling (QRA-2)**

1386 Following completion of process development studies (DoE-1 and DoE-2), a greater
1387 understanding of the risks to drug product quality associated with the roller compaction
1388 and milling stages has been developed. Cause and effect relationships have been
1389 identified that link input materials, process parameters and attributes of in-process
1390 materials to drug product quality.

1391

1392 Understanding of these cause and effect relationships has led to identification of the target
1393 output attributes and a control strategy for the roller compaction and milling stages to
1394 ensure that product of requisite quality is consistently manufactured. As a consequence
1395 of these controls, the probability of failure modes being realized has been lowered and the
1396 risks reduced.

1397

1398 In addition, these experimental studies have also allowed for the development of more
1399 appropriate tests to measure key in-process parameters and potential critical quality
1400 attributes. Therefore, earlier detection becomes possible and the detectability score for

1401 failure modes is improved, thus leading to a reduction in the level of risk. With the use of
 1402 more appropriate tests to enable earlier detection, the severity of a failure mode may be
 1403 lowered and again, the level of risk is reduced. Key tests and acceptance criteria that have
 1404 been identified include:

- 1405
- 1406 • NIR for ribbon density
- 1407 • Discriminatory dissolution Q=80%
- 1408

1409 With the increased understanding gained from these experimental studies and the
 1410 establishment of appropriate controls, a re-evaluation of the initial quality risk assessment
 1411 was undertaken (QRA-2). This is summarized in **Figure 30** which includes the initial risk
 1412 priority numbers for QRA-1.

1413

1414 **Figure 30: Final Risk Assessment (QRA-2) for the Roller Compaction and Milling**
 1415 **Stages**

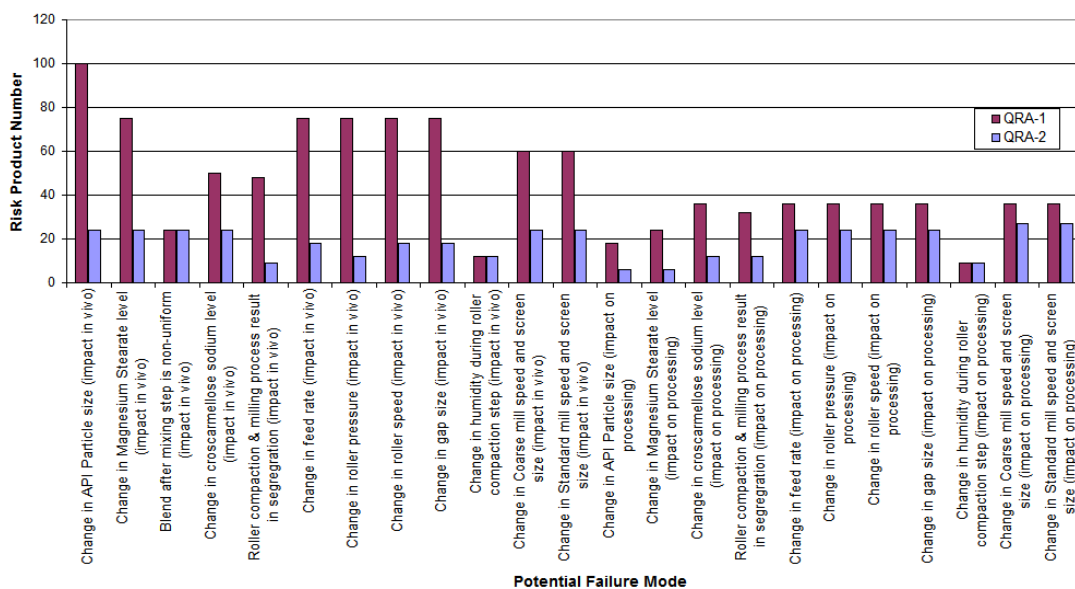

1416

1417

1418 From this risk assessment, it can be seen that the level of risk has been reduced for both
 1419 failure effects that could impact *in vivo* performance, and failure effects that could impact
 1420 upon processing and product physical quality.

1421

1422 For the failure effects associated with formulation variables (acetriptan particle size,
 1423 magnesium stearate level, croscarmellose sodium level) the level of risk has been reduced
 1424 on the basis of knowledge and understanding gained from the experimental studies and
 1425 the controls applied.

1426

1427 In summary, by a process of risk assessment, risk evaluation and subsequent risk control,
 1428 identification of the target output attributes and control strategy for the roller compaction

1429 and milling stages of the ACE tablets drug product process have been demonstrated that
 1430 minimize the risks to drug product quality associated with these processing stages.

1431 **4.4 Process Optimization – Lubrication Unit Operation**

1432 **4.4 A Lubrication Blending**

1433 Following the roller compaction and milling, the milled granulation is blended with
 1434 extragranular excipients in a second blending operation. The granules are mixed with
 1435 0.25% magnesium stearate (as lubricant) and 5% talc (as glidant). Since NIR monitoring
 1436 of the blend is not capable of fully measuring the lubrication process (i.e. over-
 1437 lubrication), a traditional method (fixed blending range based on a number of revolutions)
 1438 is used to establish the end-point of blending. Based on the development data, the
 1439 blending parameter targets listed in **Table 13** are acceptable for the proposed commercial
 1440 scale lubrication blending process. Because studies have shown that wide variations in
 1441 both blending time and blender fill volume have negligible impact on any CQA, this unit
 1442 operation is considered robust and has no critical process parameters.

1443 **Table 13: Process Parameter Targets for Lubrication**

Process Parameter	Proposed process target
Revolutions	75
Fill volume	53%

1444 Development and scaling of the lubrication blending process was performed at the 1 kg
 1445 lab scale with a 5 L capacity diffusive blender and at the 50 kg pilot plant scale with a 200
 1446 L capacity diffusive blender. Charging approximately half of the granulation, sequentially
 1447 charging the extragranular excipients, and then charging the remaining granulation
 1448 accomplished loading in all cases.

1449 An initial risk assessment was conducted for this blending step. The cause and effect
 1450 matrix analysis shown in **Table 14** indicated that the potential effect of lubrication on the
 1451 release of drug from the dosage form as measured by dissolution and appearance required
 1452 additional investigation.

1453 **Table 14: Cause and Effect Matrix Risk Analysis for Lubrication**

1454

Critical Quality Attribute	Identity	Content Uniformity	Assay	Dissolution	Impurities	Appearance
Preliminary Risk Assessment	Low	Low	Low	High	Low	Low

1455

1456 **Low Risk: Based on scientific understanding or prior knowledge**

1457 **Potential Higher Risk**

1458 Although dissolution is a critical quality attribute, a statistically significant dependence (p
 1459 < 0.10) of dissolution on blending parameters was not observed at the lab scale. Also, a
 1460 dependence of compressing performance on blender rotational speed was not observed at
 1461 the lab scale; and because free flowing materials are reported in the literature to mix at a
 1462 rate independent of blender rotational speed, the blender rotational speed was not
 1463 considered an important parameter upon scale up. Total number of revolutions and fill
 1464 volume are known to influence mixing uniformity and rate of mixing (respectively) in a
 1465 blending operation, therefore these parameters were retained for study in blending
 1466 development at the pilot scale. The metric by which sufficient mixing was confirmed was
 1467 by the level of tablet picking or sticking.

1468 To investigate the impact of fill volume and number of revolutions on compressed tablet
 1469 appearance, a full factorial 2-factor 3-level DoE was performed at the pilot scale using the
 1470 acceptable quality limits (AQL) for visual inspection of 1250 tablets as the response
 1471 variable. The granules used in this study contained 2% magnesium stearate to represent a
 1472 worst case scenario for potential over-lubrication. Tablets were inspected for each
 1473 condition and acceptable limits were defined by the quality system. Because the
 1474 relationships between the DoE factors and degree of mixing are already qualitatively
 1475 described in mixing theory, the DoE was performed in order to define process targets and
 1476 demonstrate product robustness around the proposed targets. The results are shown in
 1477 **Table 15** and in all cases acceptable tablets were produced.

1478 **Table 15: DoE Results: AQL Observations as a Response to Fill Ratio and Number**
 1479 **of Revolutions (<25 cosmetic observations acceptable)**

	$N_{rev}=50$	$N_{rev}=75$	$N_{rev}=100$
Fill=40%	3	3	1
Fill=50%	8	6	2
Fill=60%	19	15	5

1480

1481 To confirm the lab scale results showing that tablet hardness and release rate are not a
 1482 function of blending parameters, tablet hardness and dissolution were also investigated as
 1483 a response to the DoE factors at the pilot scale and the results are shown in **Figure 31** and
 1484 **Figure 32**. The results confirm that tablet hardness and dissolution are indeed
 1485 independent of blend parameters and that there is no risk in over-blending over the ranges
 1486 studied. While the main effects plot did exhibit an apparent relationship between drug
 1487 release and fill level, it was not a statistically significant effect.

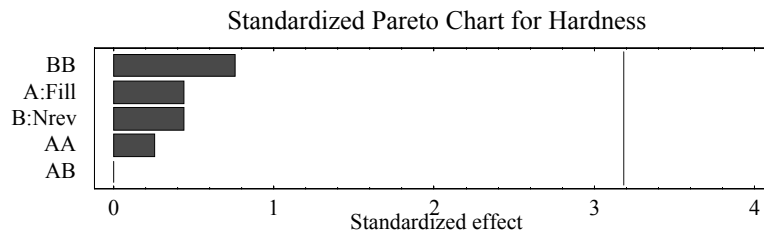
1488 **Figure 31: Effect of Blending Parameters on Tablet Hardness**

1489

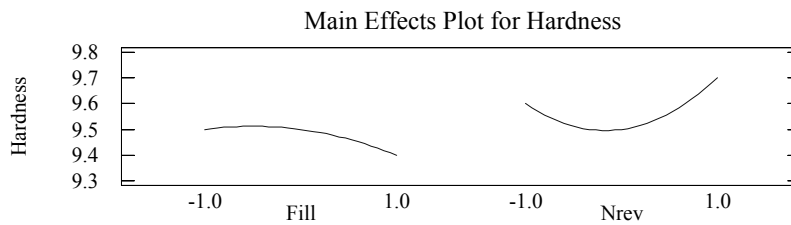

1490

1491

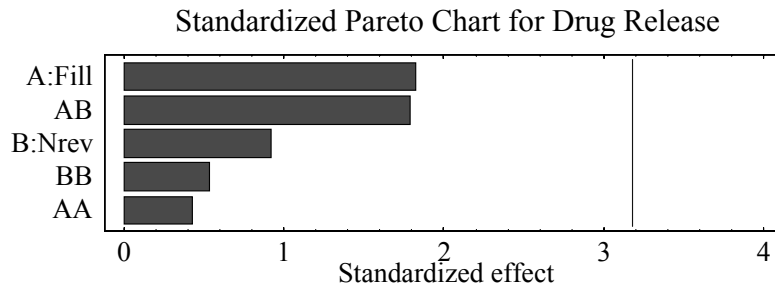
 1492 **Figure 32: Effect of Blending Parameters on Drug Release at 30min**

1493

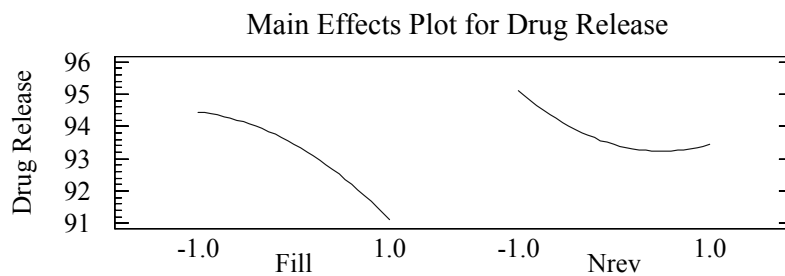

1494

1495 It should be noted that when the blending was completed using a very high number of
 1496 revolutions ($N_{rev} = 150$) a reduction in dissolution rate was observed. Although the tablets
 1497 still met the dissolution acceptance criteria this indicated that blending for an extreme
 1498 number of revolutions could affect wettability and should be avoided. In addition,
 1499 evaluation of compression data indicated that higher compressing forces were required to
 1500 produce tablets of the desired hardness when materials were blended for extended times.

1501 NIR measurements cannot predict over-lubrication, therefore an endpoint based on
1502 number of revolutions is recommended.

1503 A re-examination of the risk associated with this unit operation demonstrated that all risks
1504 are low based on the experimental work described. This is reflected in **Table 16**.

1505 **Table 16: Cause and Effect Matrix Risk Analysis for Lubrication**

1506

Critical Quality Attribute	Identity	Content Uniformity	Assay	Dissolution	Impurities	Appearance
Final Risk Assessment	Low	Low	Low	Low	Low	Low

1507

1508 **Low Risk**

1509 **High Risk**

1510 The blending process will be scaled to commercial size based on classical scale-up rules
1511 for free flowing materials¹. **Table 13** lists the commercial target lubrication parameters
1512 based on keeping the number of revolutions invariant to scale. A summary of target
1513 lubrication parameters across scales is given in **Table 17**.

1514 **Table 17: Summary of Scale Up Lubrication Parameters**

Scale	Amount (kg)	Blender Capacity (L)	Blending Speed (rpm)	Blending Time (min)	N _{rev}	Volume Fill Ratio
Laboratory	1	5	9	8	72	40%
Pilot	50	200	5	15	75	50%
Commercial	400	1500	3	25	75	53%

1515 As long as diffusive blending is employed, it is proposed that changes to site, scale and/or
1516 target process parameters can be made within the company's quality system due to the
1517 proven robustness of the system and negligible impact on CQAs,

1518 **4.5 Process Optimization – Tablet Compression Unit Operation**

1519 **4.5.A Introduction**

1520 Following blending with extragranular excipients, the manufacturing process utilizes a
1521 compression step to produce tablets that meet the requirements of the Critical Quality
1522 Attributes. The ACE compression manufacturing process flow is provided in **Figure 33**.
1523

¹ Pharmaceutical Process Scale-up, edited by Michael Levin, Chapter: Batch Size Increase in Dry Blending and Mixing, A.W. Alexander, F.J. Muzzio pp. 115-132 Marcel Dekker, NY (2002) ISBN: 0-8247-0625-0

1524 **Figure 33: ACE Tablet Compression Process Flow**

1525

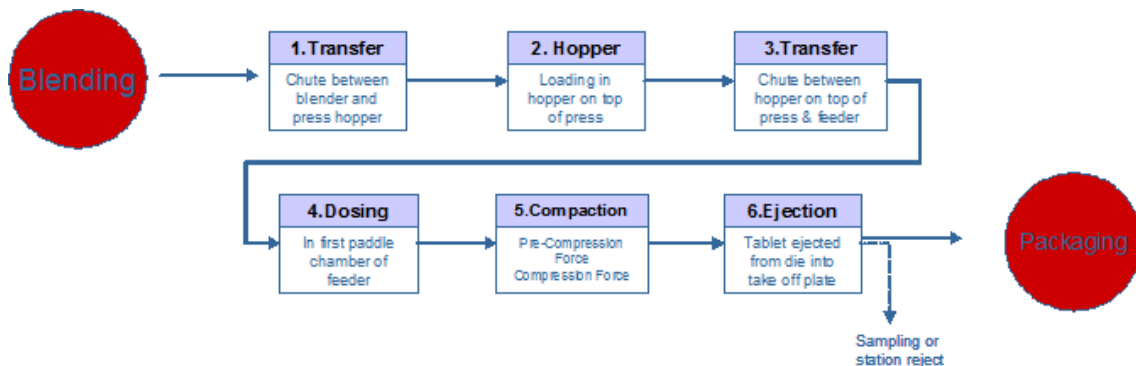

1526

1527

1528 All variables relevant to the compression process were identified using an IPO (Input,
 1529 Process, Output) diagram (**Figure 34**). A parameter/attribute matrix of all potentially
 1530 significant parameters for compression was developed. Based on prior knowledge and
 1531 process experience, the variables most likely to influence the quality of the drug product
 1532 were identified. The effect of lubrication blending on tablet hardness and tablet
 1533 appearance had been investigated previously and is described in the aforementioned
 1534 lubrication section; therefore they will not be considered further here.

1535

1536 A risk assessment was then undertaken using FMEA, to establish those variables that are
 1537 likely to pose the greatest risk to the quality of the product and be associated with a drug
 1538 product CQA. A summary of the highest potential risks identified by the FMEA is
 1539 provided in **Table 18**. The variables identified as a result of the FMEA as highest
 1540 potential risk to quality and requiring further evaluation are given in **Table 20**.

1541

1542 **Figure 34: IPO Diagram for ACE Compression Step**

 1543
 1544
 1545
 1546

Table 18: Summary of High Potential Risks from ACE Compression Step FMEA

Potential Risks	DP potential CQA impacted	RPN	Comments	Recommended Actions
Pre Compression/ Compression force too high	Dissolution Hardness (if a CQA)	High	High hardness is known to impact disintegration and dissolution	Investigate impact of pre-compression and compression forces
Pre Compression/ Compression force too low	Dissolution Hardness (if a CQA) Appearance	High	Decreased compaction leading to softer tablet	Investigate impact of pre-compression and compression force
Decrease in the blend bulk density	Dissolution Content Uniformity	High	Ribbon density too low	Assess impact of blend made from different ribbon densities
Increase in the blend bulk density	Dissolution Content Uniformity	High	Ribbon density too high	Assess impact of blend made from different ribbon densities
Feeder speed too high	Hardness Tablet Weigh variation	High	Variation in die fill due to high speed	Optimise feeder speed and feeder fill
Press speed too high	Dissolution Hardness (if a CQA) Tablet weight Appearance	High	Tablet hardness too low Capping of tablets	Feeder speed and press speed must be optimised to achieve correct weight
Non uniform tablet weight	Content Uniformity	High	Impacted by weight control throughout the compression run	Assess continuity of 6 batches of tablets produced at scale, across batch and compare

 1547
 1548

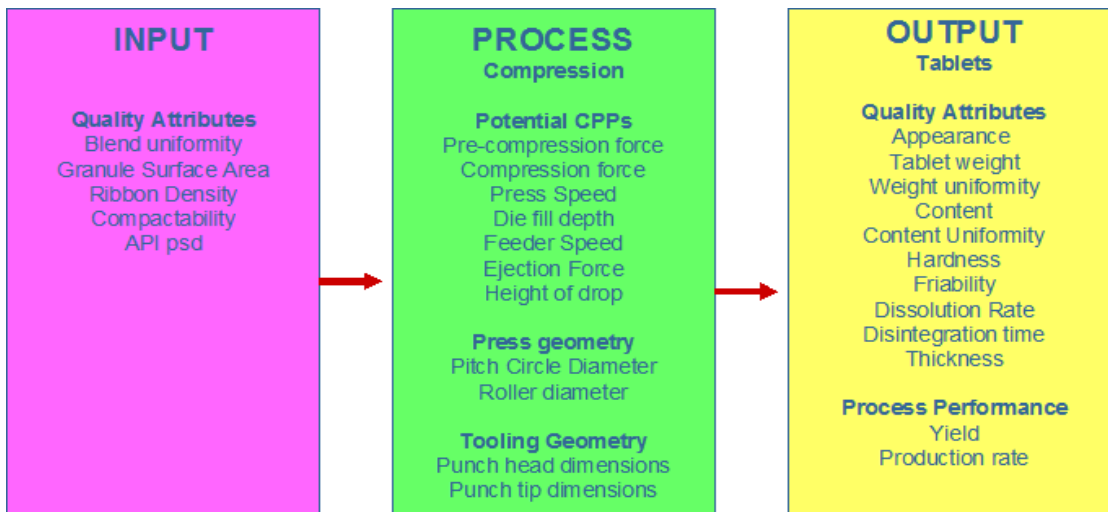
1549 **Table 19: Potentially Important Compression Process Variables and Quality**
 1550 **Attributes**

1551

Input Material Attributes	Compression Process Parameters	Tablet Quality Attributes
Blend uniformity Granule surface area Ribbon density Acetripitan particle size	Pre-Compression force Compression force Press speed Feeder speed Feeder fill depth	Appearance Tablet weight Weight uniformity Content Uniformity Hardness Friability Dissolution rate Disintegration time

1552

1553 A series of multivariate analyses, including DoE, was undertaken to investigate the
 1554 relationship between the input attributes, compression process parameters and output
 1555 attributes.

1556

1557 Initially a screening DoE (DoE 1) was undertaken to provide an assessment of the impact
 1558 of the compression process parameters on the tablet quality attributes. The screening
 1559 study confirmed that feeder speed and feeder fill have no impact on quality over the
 1560 ranges investigated; therefore, feeder speed and feeder fill depth were eliminated for
 1561 further studies.

1562

1563 A detailed statistical design of experiments (DoE 2) was then performed to investigate
 1564 more fully the remaining compression process parameters and identify the target ranges.
 1565 The DoE looked at the impact of pre-compression force, compression force and press
 1566 speed on tablet hardness, friability, disintegration time, weight and dissolution. DoE 2
 1567 identified output attributes which were then used in a third DoE (DoE 3) to investigate the
 1568 impact of the ranges of input material attributes identified from the previous unit
 1569 operations.

1570 **4.5.B Compression DoE 2**

1571 Although pre-compression force and compression force are listed as process parameters,
 1572 they are actually dependant on equipment operating variables and the properties of the
 1573 blend being compressed. Pre-compression force and compression force are a direct
 1574 function of the distance between upper and lower punch faces, as long as all other factors
 1575 such as tablet weight and other machine parameters are kept constant. Under these
 1576 conditions the pre-compression and compression force can be increased by decreasing the
 1577 distance between punches. The DoE was performed on a rotary tablet press on one batch
 1578 of blend (prepared with acetripitan particle size of $d_{90} = 35\text{micron}$ and with 1.5%
 1579 magnesium stearate), made from ribbon with relative density in the middle of the target,
 1580 with tablet weight set at 200mg, press speed varied and all other machine parameters kept
 1581 constant, in order to allow evaluation of pre-compression and compression force as
 1582 process parameters.

1583 A central composite design was used comprising 17 runs consisting of three centre points,
 1584 eight factorial points and six star or alpha points. The upper and lower levels of each
 1585 variable were chosen to bracket the expected target tableting process parameters. The
 1586 process parameter ranges investigated are given in **Table 20**.
 1587

1588 **Table 20: Process parameters ranges investigated in compression DoE 2**

1589

Compression Process Parameters	Lower	Upper
Pre-Compression Force (kN)	0.3	2.9
Compression Force (kN)	7.4	12.9
Press Speed (tablets per hour)	26000	94000

1590

1591 **Results of Compression DoE 2**

1592 An ANOVA was used to evaluate whether the factors had a statistically significant effect
 1593 on each response. Significant factors were selected using stepwise regression, and were
 1594 included in the model if their p-value was less than 0.05. None of the factors had a
 1595 statistically significant response for friability, therefore friability will be considered
 1596 insignificant within the ranges studied. Each of the other responses is discussed below.

1597 **Hardness**

1598 The summary of fit and analysis of variance results show that a very good model was
 1599 obtained for hardness. Compression force is the most important factor impacting tablet
 1600 hardness, indicated by a high sum of squares value (**Table 21**). Pre-compression force on
 1601 its own does not have a significant effect on tablet hardness; however the interaction of
 1602 compression force and pre-compression force is statistically significant. The interaction of
 1603 press speed and compression force and the squared term for press speed are the other
 1604 significant factors. The sums of squares for all significant terms, except compression
 1605 force, are relatively small indicating that they are not major contributors to the model.
 1606 Although these terms are statistically significant and are included in the model to provide
 1607 the best fit, from a practical perspective, compression force is the only factor that impacts
 1608 hardness significantly. The effect of compression force on hardness is shown in **Figure**
 1609 **35**. As expected, an increase in compression force produces harder tablets. The slight
 1610 interaction of compression force and pre-compression force is also shown in **Figure 35**.
 1611 At low compression forces, tablet hardness is reduced slightly as pre-compression force is
 1612 increased. This relationship is reversed at high compression forces.
 1613

1614 **Table 21: Effect tests for Hardness**

1615

Source	DF	Sum of Squares	F Ratio	Prob>F
A:Compression Force	1	142.5	475.4	<0.0001
B:Pre-Compression Force	1	0.016	0.054	0.82
C:Press speed	1	0.299	1.00	0.34
A:Compression Force* B:Pre-Compression Force	1	2.323	7.75	0.019
A :Compression Force*C:Press Speed	1	5.154	17.2	0.0020
C:Press Speed*C:Press Speed	1	3.007	10.03	0.0100

1616

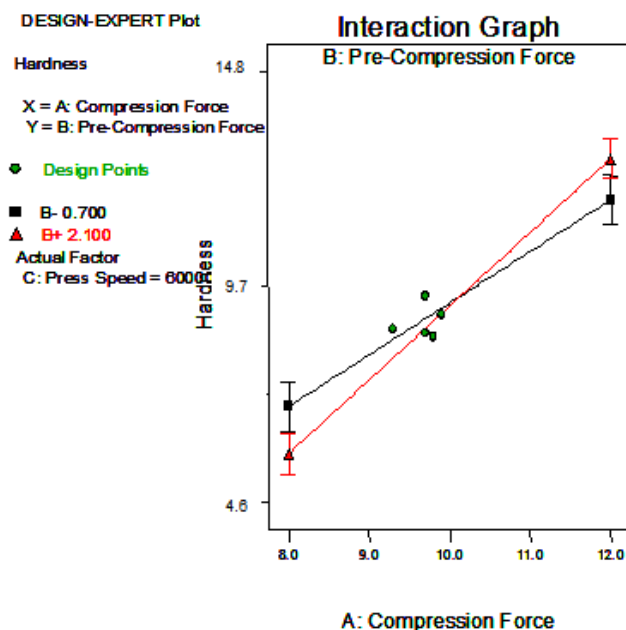
 1617 **Figure 35: Effect of Compression Force on Tablet Hardness**

1618

 1619 **Dissolution**

1620

1621 A very good model was obtained for the relationship between compression force and
 1622 dissolution at 15 minutes. Compression force and the squared term for compression force
 1623 are the important factors (**Table 22**). There is a significant decrease in dissolution as
 1624 compression force is increased (**Figure 36**). Dissolution decreases from 88% at a
 1625 compression force of 8 kN to 64% at a compression force of 12 kN. As discussed in the
 1626 previous section, an increase in compression force increases tablet hardness. Harder
 1627 tablets would be expected to show slower dissolution and a plot of dissolution at the 15
 1628 minute time point versus tablet hardness (**Figure 37**) shows that this is indeed the case.

1629

1630 A similar model was obtained for dissolution at the 30 minute time point (**Table 23**).
 1631 Dissolution drops from 95% at a compression force of 8 kN to 85% at a compression
 1632 force of 12 kN (**Figure 38**). As seen with the 15 minute dissolution time point, a very
 1633 good correlation is obtained between tablet hardness and dissolution at 30 minutes
 1634 (**Figure 39**).

1635
 1636 Since dissolution is a critical quality attribute, compression force is a potential critical
 1637 process parameter because of its significant effect on dissolution. Because of the good
 1638 correlation between tablet hardness and dissolution, tablet hardness is considered a
 1639 surrogate for dissolution. Therefore controlling tablet hardness will control dissolution
 1640 (assuming the API particle size, ribbon density and magnesium stearate levels are
 1641 appropriately controlled). Models developed as a result of the compression DoEs have
 1642 been used to set appropriate in-process measurement limits for tablet hardness, to ensure
 1643 that appropriate dissolution is obtained. Dissolution testing on final product will not be
 1644 undertaken routinely.

1646 **Table 22: Effect tests for 15min Dissolution**

1647

Source	DF	Sum of Squares	F Ratio	Prob>F
A:Compression Force	1	1399.5	170.4	<0.0001
A:Compression Force* A:Compression Force	1	126.2	15.4	0.0015

1648

1649

1650 **Figure 36: Effect of Compression Force on Tablet Dissolution at 15min**

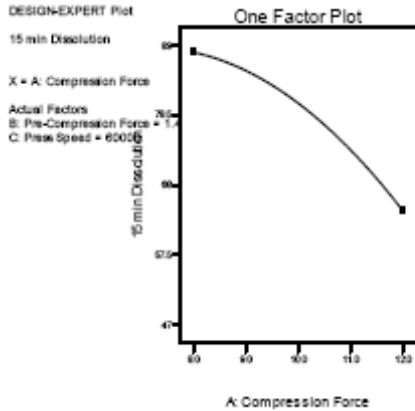
 1651
 1652

1653

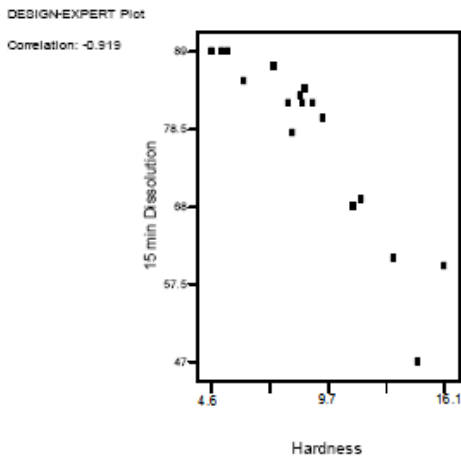
 1654 **Figure 37: Correlation between Tablet Hardness and Dissolution at 15 Minutes**

1655

1656

 1657 **Table 23: Effect tests for 30min Dissolution**

1658

Source	DF	Sum of Squares	F Ratio	Prob>F
A:Compression Force	1	246.4	78.1	<0.0001
A:Compression Force* A:Compression Force	1	84.7	26.8	0.0001

1659

1660 **Figure 38: Effect of Compression Force on Tablet Dissolution at 30min**

1661

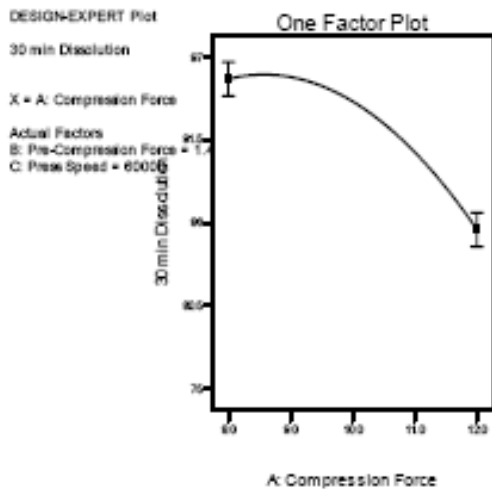

1662

1663

1664 **Figure 39: Correlation between Tablet Hardness and Dissolution at 30 Minutes**

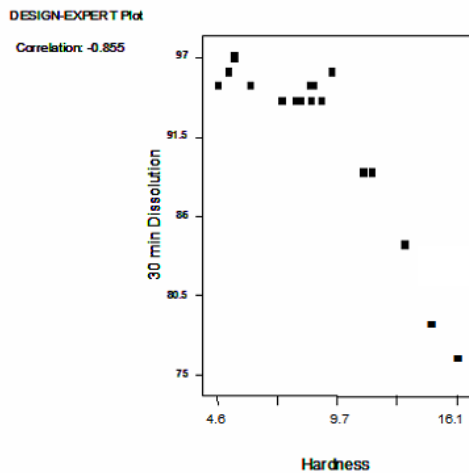

1665

1666 **Disintegration Time**

1667 A very good model was obtained for disintegration time. As seen with the previous
 1668 responses, the main factor impacting disintegration time is compression force (**Table 24**).
 1669 Disintegration time is highly correlated with dissolution at 30min (**Figure 40**).

1670 **Table 24:** Effect tests for Disintegration Time

1671

Source	DF	Sum of Squares	F Ratio	Prob>F
A:Compression Force	1	14462.2	215	<0.0001
B:Pre-Compression Force	1	47.6	0.71	0.42
C:Press speed	1	431.5	6.42	0.0278
A:Compression Force* A:Compression Force	1	5638.2	83.84	<0.0001
A :Compression Force*B:Pre-Compression Force	1	565.2	8.40	0.0145

1672

 1673 **Figure 40:** Correlation between Disintegration Time and Dissolution at 30min

1674

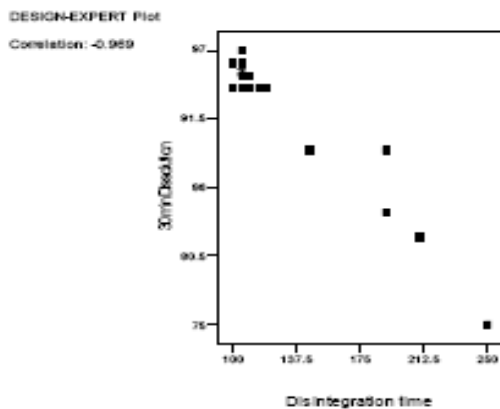

1675

 1676 **Conclusion from Compression DoE 2**

1677

1678 Based on process understanding and risk assessment (utilizing FMEA), compression was
 1679 determined to be a critical step in the manufacture of ACE tablets. Compression force was
 1680 identified as a potential critical process parameter, because of its significant impact on the
 1681 critical quality attribute of dissolution if not adequately controlled. Pre-compression force
 1682 and press speed are included in some of the models to get a better statistical fit, however
 1683 their contributions are not significant within the ranges studied.

1684

1685 The compression force required to obtain a particular tablet hardness can be influenced by
 1686 a number of factors including properties of the blend and equipment parameters, therefore
 1687 the compression force required to produce tablets with the required hardness could vary
 1688 from batch to batch and from machine to machine. The equipment parameters are
 1689 established by controlling the target output attributes for compression, the output
 1690 attributes are monitored and controlled by in-process measurements,

1691

1692 The results of the compression DoE were used to define the process output attributes for
 1693 compression presented in **Table 25**. The lower limit of the hardness is based on handling
 1694 studies. The upper hardness limit is based on achieving acceptable dissolution. For tablets

1695 with 12kP hardness, the compression DoE model predicts tablet dissolution of at least
 1696 80% at the 30 minute time point.

1697
 1698 During batch set-up the compression force is set at a value that produces tablets which
 1699 exhibit the target attributes as indicated by the in process measurements. Once the
 1700 appropriate compression force is established, it is controlled within specified limits by a
 1701 feedback control loop.

1702

1703 **Table 25: Output Attributes for Compression Unit Operation**

1704

Process Measurement	Target Properties
Mean core weight 20 cores	194-206mg
Individual core weights	190-210mg
Crushing strength (Hardness) 5 cores	5-12kP

1705

1706 **4.5.C Compression DoE 3**

1707

1708 DOE 2 established the target attributes (**Table 25** above) which describe the desired
 1709 output from the compression process. As the compression process is the final unit
 1710 operation following a number of other process steps, the input to the compression process
 1711 will have inherent variability, Therefore the impact of process input variables on the
 1712 output from the compression step was investigated in order to ensure that the tablets
 1713 produced from the variable inputs met the target ranges for the tablet CQAs.

1714

1715 A DoE study was undertaken to assess the impact of variable inputs on the compression
 1716 process. The upper and lower level of each variable were chosen to bracket the expected
 1717 range of process inputs (identified from optimization of the formulation and previous
 1718 process stages) and target tableting process parameters . The input variables and process
 1719 parameter ranges investigated are given in **Table 26**. The experiments were performed on
 1720 a rotary tablet press.

1721

1722 **Table 26: Input variables and process parameter ranges investigated**

Input Variable and Compression Process Parameters	Lower	Upper
Magnesium Stearate level	1%	2%
Acetriptan particle size (d_{90} - micron)	10	40
Relative ribbon density	0.68	0.81
Granule GSA ($\text{cm}^2/100\text{g}$)	12,000	41,000
Hardness (kN)	5	12
Press Speed (tablets per hour)	26000	94000
Pre-Compression force (kN)	0.3	2.9
Compression Force (kN)	as required to achieve hardness limits	

1723

1724 All of these variations reflect the likely variability of inputs which will be experienced
 1725 during routine manufacture of ACE tablets. The impact of the variable inputs and process
 1726 parameters on tablet weight, friability, disintegration time, and dissolution was
 1727 determined.

1728

1729 All tablets produced met the acceptable ranges for the critical product attributes defined in
 1730 the target product profile. In the target product profile a dissolution limit of not less than
 1731 75% in 30 minutes was required. In light of subsequent *in vivo* data, it is now known that
 1732 a specification of not less than 80% in 30 minutes is required for dissolution (see Section
 1733 4.6, The *in vivo* investigation). From the experiments conducted, and in line with
 1734 predictions from previous experiments, a reduction in dissolution rate was observed as the
 1735 acetriptan particle size increased. At high acetriptan particle size and high magnesium
 1736 stearate level, the dissolution data did not meet the criterion for dissolution of not less
 1737 than 80% at 30 minutes, confirming the formulation component levels established
 1738 previously .

1739

1740 Some example plots of dissolution versus hardness are shown in **Figure 41**. The plots
 1741 show that tablets made from acetriptan with low particle size ($d_{90} = 10$ micron) show
 1742 almost constant dissolution across the range of acceptable hardness. For tablets made
 1743 from acetriptan with larger particle size ($d_{90} = 40$ micron), the plots show that dissolution
 1744 reduces with increased hardness but still lies within the acceptable ranges.

1745

1746 **Figure 41: Example Plots of Dissolution versus Hardness for Different Tablet**
 1747 **Variants**

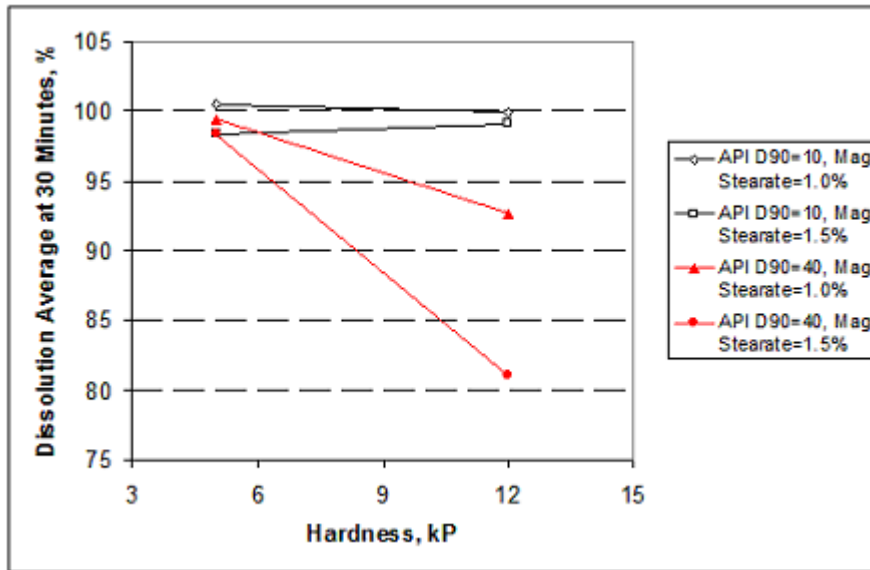

1748
 1749

1750 Therefore, it can be concluded that the design space encompasses all the ranges explored
 1751 in **Table 26**, however the amount of magnesium stearate must be limited (1-1.75% instead
 1752 of 1-2%) in tablets with high acetriptyan d_{90} particle size (35-40 micron).

1753

1754 Additionally it is concluded that, batches of ribbon which exhibit densities towards the
 1755 lower end of the acceptable specification range require pre-compression forces and
 1756 compression forces towards the upper end of the ranges described in **Table 27**.

1757

1758 These findings led to definition of example operating conditions described in **Table 27**,
 1759 which sit within the input variables and process parameter ranges given in **Table 26**.

1760 These are operating conditions for the rotary tablet press used in this study which, when
 1761 complied with, result in the process operating successfully and tablets which meet the
 1762 required process output for compression are produced.

1763

1764 **Table 27: Example compression process operating conditions**

1765

Compression Process Parameters	Relative ribbon density 0.68 to 0.75	Relative ribbon density 0.75 to 0.81
Pre-Compression Force (kN)	1.0 – 2.9	0.3 – 2.0
Compression Force (kN)	9.0 – 13.5	6.8 – 11.0
Press speed (tph)	30000 - 90000	30000 - 90000
Feeder Speed (rpm)	10 - 18	10 - 18

1766

1767 **Content Uniformity**

1768 The impact of blend uniformity on content uniformity has already been discussed. To
 1769 ensure content uniformity of the tablets is maintained by control of the tablet weight
 1770 throughout the duration of the compression process, tablet samples were collected at
 1771 approximately 15 minute intervals during the compression of six batches of ACE tablets
 1772 at pilot scale. Samples were taken from a total of 25 sample points for each batch and
 1773 three tablets from each sample point were analyzed. Data for one batch of tablets is shown
 1774 in **Figure 42**. The data shows excellent content uniformity that exceeds the current
 1775 harmonized content uniformity monograph and no trends are observed during the
 1776 compression run.

1777
 1778 The data from the other 5 batches were very similar with the RSD of all individual results
 1779 being $\leq 1.9\%$ for all six batches.

1780

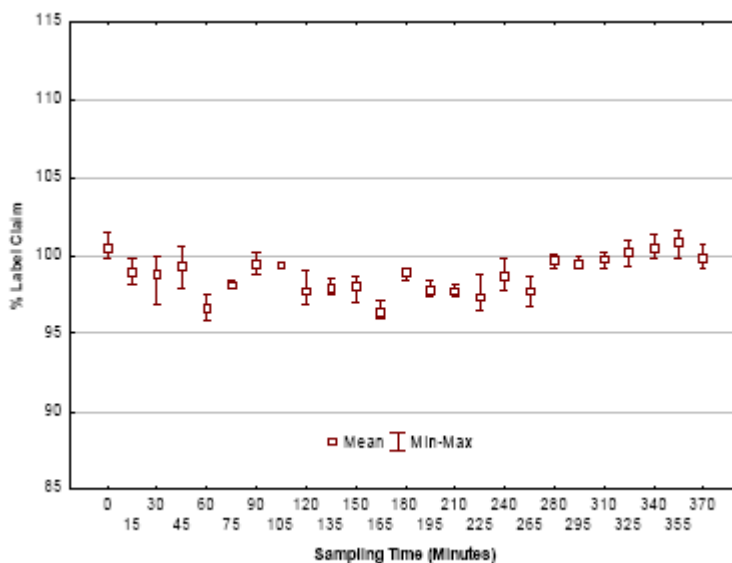
 1781 **Figure 42: Tablet Content Uniformity: data plot for one of six tablet batches**

1782

1783

1784 From the data above a plot of %Target Weight versus % Label Claim was produced
 1785 (**Figure 43**). The plot shows that % target weight correlates with % label claim and
 1786 indicates that weight can be used as a predictive surrogate for content uniformity.

1787

1788 This work gives additional confidence that tablet content uniformity is being adequately
 1789 controlled during manufacture of ACE tablets.

1790

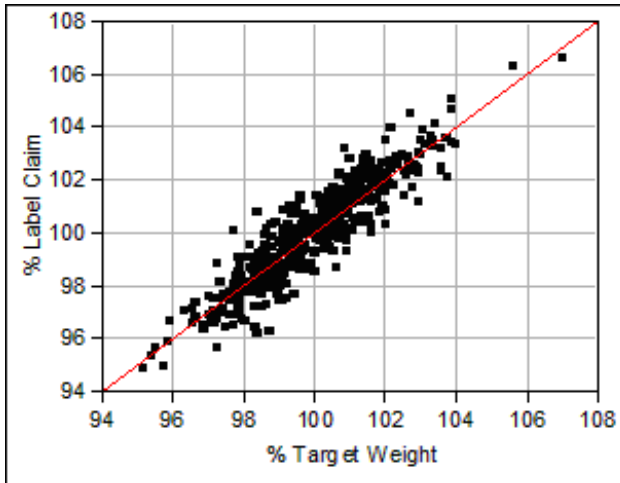
1791 **Figure 43: Plot of %Target Weight versus % label Claim**

 1792
 1793

 1794 **Operating Ranges for Compression**

 1795 Based on the understanding of compression, appropriate process operating conditions will
 1796 be determined to accommodate different types of rotary tablet press. These conditions
 1797 may be different to those exemplified in **Table 27**, but will result in tablets which meet
 1798 the output attributes for compression given in **Table 25**. The proven acceptable ranges
 1799 for compression are represented in **Figure 44** below.
 1800

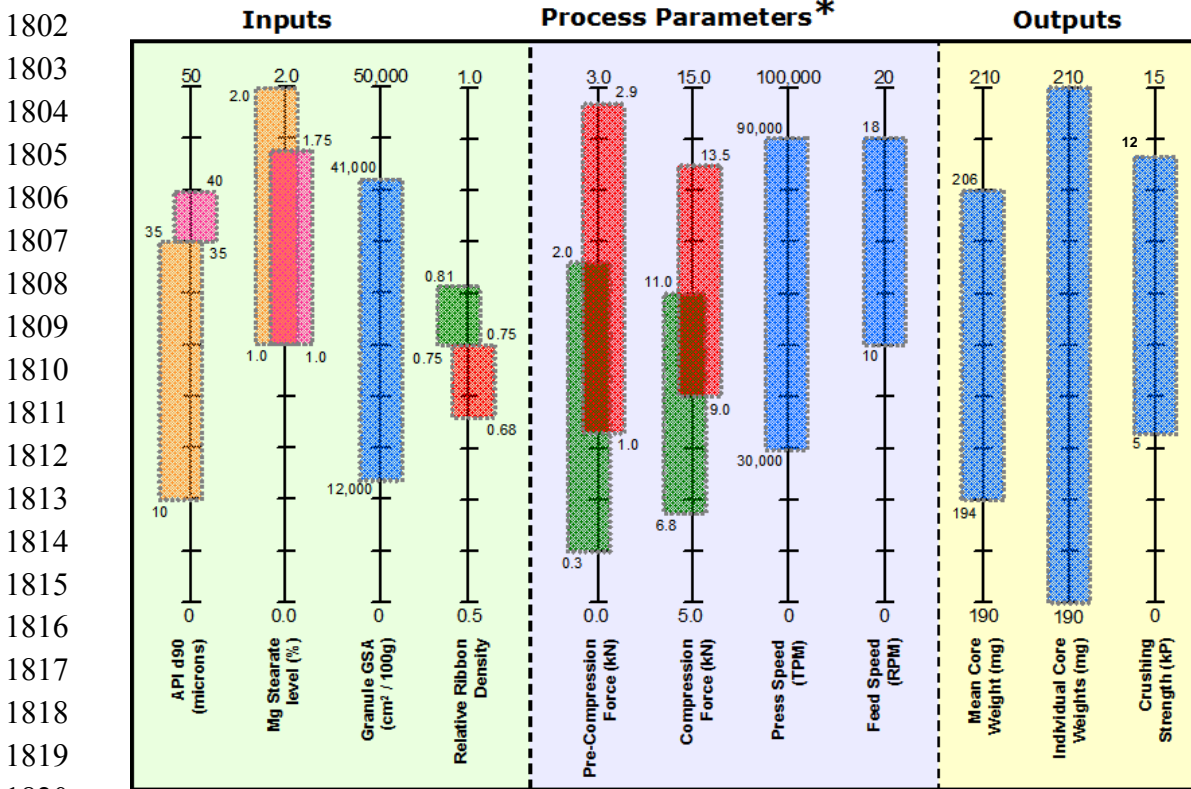
1801 **Figure 44: Representation of Proven Acceptable Ranges for Compression**



1821 API d90 10 to 35 microns Relative Ribbon Density 0.68 to 0.75
 1822 API d90 35 to 40 microns Relative Ribbon Density 0.75 to 0.81

1823 * Appropriate process parameters will be determined to accommodate different types of rotary tablet press
 1824

1825 **Control Strategy for Compression**

1826 The control strategy for compression is to maintain the tablet attributes within the
 1827 required ranges listed in **Table 25**. The target compression force required to produce
 1828 tablets with acceptable quality attributes is established using the in process measurements
 1829 at the beginning of the run. The compression force is measured throughout the run and
 1830 compared to the target compression force. Deviations from the target compression force
 1831 result in tablet weight corrections by adjusting the fill depth. Upper and lower limits of
 1832 compression force are set and any tablet that registers a compression force outside these
 1833 limits is automatically rejected by the tablet press.
 1834

1835 **Quality Risk Management**

1836 In order to confirm sufficiently that the control strategy defined for compression reduces
 1837 the risk of producing poor quality product and to assess whether any of the process
 1838 parameters are Critical Process Parameters, the risk assessment (FMEA) was repeated.
 1839 **Table 28** below shows the FMEA updated for the high risk attributes and parameters

1840 identified previously, based on the process understanding gained and control strategy
 1841 defined. For all the parameters and attributes identified the risk to product quality is now
 1842 low, therefore the process parameters are not considered to be Critical Process Parameters
 1843 and the input material attributes are not Critical Quality Attributes, though the parameters
 1844 and attributes still must be controlled.
 1845

1846 **Table 28: Updated Compaction FMEA**

1847

Potential Risks	DP potential CQA impacted	RPN	Recommended Actions	Comments
Pre Compression/ Compression force too high	Dissolution Hardness (if a CQA)	Low	Compression force is set based on in process measurements and then controlled by feedback control loop	Likelihood of compression force being set too high is low, and will be monitored throughout the run to maintain desired level. Occurrence and detection reduced so not critical
Pre Compression/ Compression force too low	Dissolution Hardness (if a CQA) Appearance	Low	Compression force is set based on in process measurements and then controlled by feedback control loop	Likelihood of compression force being set too low is low, and will be monitored throughout the run to maintain desired level. Occurrence and detection reduced so not critical
Decrease in the blend bulk density	Dissolution Content Uniformity	Low	Ribbon density measured and controlled during roller compaction, compression process can cope with extremes of ribbon density	Likelihood of blend with low bulk density is minimal. Not critical.
Increase in the blend bulk density	Dissolution Content Uniformity	Low	Ribbon density measured and controlled during roller compaction, compression process can cope with extremes of ribbon density	Likelihood of blend with high bulk density is minimal. Not critical.
Feeder speed too high	Hardness Tablet Weight variation	Low	PAR of feeder speed identified. Tablet weight monitored throughout the run.	Tablets not meeting weights requirements are automatically rejected. Not critical.
Press speed too high	Dissolution Hardness (if a CQA) Tablet weight Appearance	Low	PAR of press speed identified.	Tablet hardness too low Capping of tablets
Non uniform tablet weight	Content Uniformity	Low	Tablet weight is monitored throughout the compression run and out of range tablets are rejected	Six batches of tablets produced at scale showed acceptable RSD for tablet content uniformity.

1848
 1849

1850 **4.6 The *In vivo* investigation**

1851 **4.6.A Rationale for study ACEPK0015**

1852

1853 Prior knowledge of the properties of acetriptan and the drug product manufacturing
1854 coupled with quality risk assessment identified drug substance, formulation and process
1855 attributes that could be critical to the final quality and performance of the product. These
1856 attributes were:

1857

1858

1. API particle size

1859

2. Ribbon density

1860

3. Levels of magnesium stearate (lubricant)

1861

1862 In order to understand the potential clinical relevance of these attributes, an *in vivo*
1863 clinical pharmacokinetics study (ACEPK0015) was conducted with five tablet variants
1864 that were manufactured using a range of parameters representative of these critical quality
1865 attributes. The selection of these variants was based on prior product knowledge, a
1866 number of detailed quality risk assessments, and screening using the dissolution method.

1867

1868 The second aim of this investigation was to establish a relationship between *in vitro*
1869 dissolution and clinical bioavailability, with the possibility of establishing an *in vitro in*
1870 *vivo* correlation (IVIVC). The dissolution method is believed to be capable of
1871 mechanistically differentiating between tablets manufactured using extremes of process
1872 and formulation parameters. However, by following the IVIVC approach, it is envisaged
1873 that this dissolution test would be used as a surrogate to pharmacokinetic studies in
1874 assuring clinical quality of ACE tablets.

1875

1876 **4.6.B Clinical pharmacokinetic study (ACEPK0015)**

1877 The variants dosed in the clinical pharmacokinetics study ACEPK0015 encompassed a
1878 range of processing and formulation parameters and were selected with the objective of
1879 achieving the greatest mechanistic understanding of the *in vivo* performance of the ACE
1880 tablets. These variants were:

1881

1882

A. Standard clinical ACE tablet: standard conditions and API $D_{90} = 10 \mu\text{m}$

1883

B. Standard clinical ACE tablet: standard conditions and API $D_{90} = 40 \mu\text{m}$

1884

C. Standard clinical ACE tablet: Process variant: highest ribbon density = 0.81

1885

D. Formulation variant: API $D_{90} = 10 \mu\text{m}$, 2.25% MgSt, ribbon density = 0.81, 3% CCS

1886

E. Worst-case variant: API $D_{90} = 40 \mu\text{m}$, 2.25% MgSt, ribbon density = 0.81, 3% CCS

1887

1888 These tablet variants were selected based on the understanding of the mechanism of
1889 dissolution retardation and represent the upper limit of the formulation and process
1890 parameters, and hence the worst-case scenario in terms of impact of dissolution and

1891 bioavailability. Variant B was manufactured using the upper-limit drug substance particle
 1892 size of 40 μm , and the knowledge that a larger particle size could affect in-vivo
 1893 performance. Variant C was manufactured from granules manufactured using the upper
 1894 limit ribbon density of 0.81, based on the knowledge that increasing the ribbon density
 1895 will reduce the dissolution rate. Variant D was selected because of the reduced level of
 1896 disintegrant, ribbon density of 0.81 and increased lubricant levels could impact in vivo
 1897 performance. Finally, variant E represents the combination of all the particle size,
 1898 formulation and process limits that demonstrates the edge of knowledge of the ACE drug
 1899 substance and product. All five, tablet variants were compressed to a hardness of 12 kP.

1900 The clinical pharmacokinetic study was conducted in a complete crossover design; 12
 1901 subjects were enrolled in the study whereby each subject received all five, tablet variants
 1902 and a non-precipitating co-solvent based oral solution. The oral solution was dosed as a
 1903 reference to allow the calculation of the *in vivo* dissolution/absorption vs. time profiles of
 1904 acetriptan by deconvolution, and to investigate any potential *in vitro-in vivo* correlation
 1905 (IVIVC). The quantitative and qualitative composition of variants A, B and C is identical.
 1906 The composition of the 5 tablets is summarised in **Table 29**.

1907 **Table 29: Composition of ACE 20mg Tablets used in Study ACECPK00015**

Variant	A, B, C	D, E	
Formulation Component	Mg/tablet (w/w%)	Mg/tablet (w/w%)	Function
Acetriptan	20 (10%)	20 (10%)	Drug substance
Microcrystalline cellulose	80 (40%)	80 (40%)	Diluent
Croscarmellose Sodium	8 (4%)	6 (3%)	Disintegrant
Magnesium stearate			Lubricant
<i>intragranular</i>	2 (1%)	4 (2%)	
<i>extragranular</i>	0.5 (0.25%)	0.5 (0.25%)	
Lactose monohydrate	79.5 (39.75%)	79.5 (39.75%)	Diluent
Talc	10 (5%)	10 (5%)	Glidant
Core tablet weight	200 mg	200 mg	

1908 **4.6.C Results**

1909 **In vitro dissolution**

1910 Prior to study ACEPK0015, the *in vitro* performance of variants A-E was evaluated using
 1911 the previously described 1.0% SLS dissolution method, with sampling at 10-minute

1912 intervals. This dissolution method was shown to discriminate between the various tablet
 1913 variants produced.

1914 The dissolution experiments (**Figure 45**) demonstrate that the dissolution method is
 1915 capable of differentiating between different variants manufactured using a wide range of
 1916 parameters that are thought to impact *in vitro* dissolution of ACE tablets by a variety of
 1917 mechanisms. As such, the dissolution method can be used to monitor changes to potential
 1918 critical product attributes.

1919

1920 **Figure 45: Average dissolution of all 5 tablet variants in the 1% SLS method**

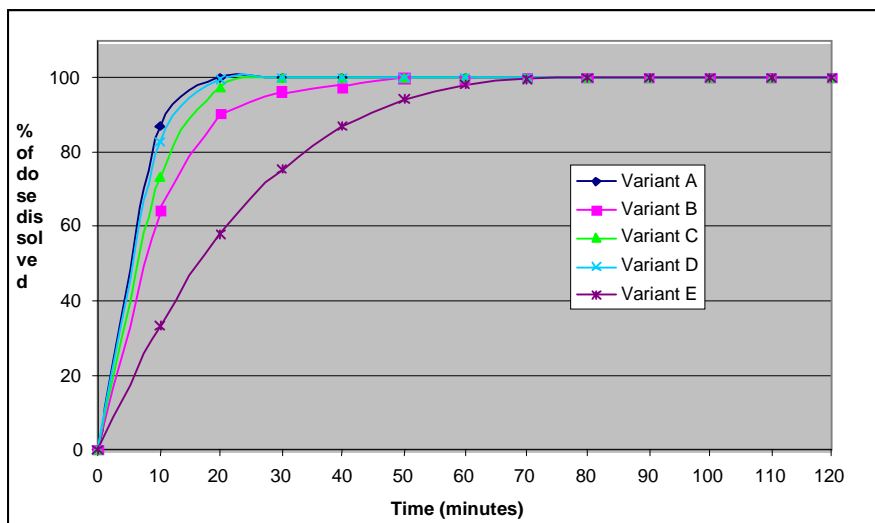

1921

1922 **In vivo investigation (ACEPK0015)**

1923 Twelve healthy subjects from a single centre completed all 6 dosing periods. The
 1924 pharmacokinetics results ($AUC_{0-\infty}$, C_{max} , t_{max} , and $t_{1/2}$) are summarized in **Table 30**.

Table 30: Mean Pharmacokinetic Parameters for the ACE Tablet Variants ($AUC_{0-\infty}$, C_{max} , t_{max} and $t_{1/2}$) all represented as Geometric Mean Values

Dosing period	N	$AUC_{(0-\infty)}$ ($\mu\text{g}\cdot\text{h}/\text{mL}$)		C_{max} ($\mu\text{g}/\text{mL}$)		t_{max} (hr)	$T_{1/2}$ (hr)
		Geomean (%CV)	Rel AUC	Geomean (%CV)	Rel C_{max}	Median	Geomean (%CV)
Oral Solution (reference)	12	8.659 (22.30)	--	0.2504 (29.37)	--	1.33	24.01 (18.36)
Variant A	12	8.450 (17.56)	0.97	0.2414 (18.36)	0.96	1.37	23.98 (26.99)
Variant B	12	8.077 (22.62)	0.93	0.2299 (24.74)	0.92	1.55	25.59 (19.66)
Variant C	12	8.359 (23.02)	0.96	0.2320 (15.77)	0.93	1.67	23.12 (22.75)
Variant D	12	8.256 (25.67)	0.95	0.2379 (15.55)	0.95	1.68	24.98 (22.62)
Variant E	12	7.010 (20.71)	0.90	0.2153 (28.3)	0.86	2.50	21.50 (24.54)

1925

1926 Following a single oral dose of 20 mg of ACE oral solution, C_{max} was achieved at a
 1927 median of 1.33 hours, with similar values observed for variants A to D. Statistical
 1928 evaluation of these data using from study ACEPK0015 the T-test at 95% CI ($p < 0.05$)
 1929 demonstrate the following key observations:

- 1930 1. C_{max} and AUC values for variants A to D and the oral solution were similar
- 1931 2. C_{max} , AUC and T_{max} of tablet variants A to D were similar
- 1932 3. C_{max} , AUC and T_{max} for variant E was different from all other variants and its
 1933 pharmacokinetic properties are considered unacceptable for this indication.

1934 4.6.D Exploration of an *in vitro-in vivo* correlation for ACE tablets

1935 These observations support the findings in the formulation study, which demonstrated an
 1936 interaction between acetriptyan particle size and magnesium stearate levels. At a hardness
 1937 of 12 kP, variant E gave unacceptable *in vivo* performance in that its T_{max} was longer than
 1938 the target product profile. The remaining 4 variants have very similar *in vivo*
 1939 performance.

1940

1941 Based on the evidence provided in this section, the development of an IVIVC was not
 1942 attempted. In terms of *in vitro* dissolution, variant E had an average dissolution rate of
 1943 75.22% in 30 minutes, and hence the specification requirement of dissolution rate of Q =
 1944 80% in 30 minutes for all units was set to ensure the suitability of ACE tablets.

1945 **Figure 46: Average plasma concentration-time profiles (0 to 48 hrs) for 20 mg ACE**
 1946 **IR variants and oral solution (geomean, n=12)**

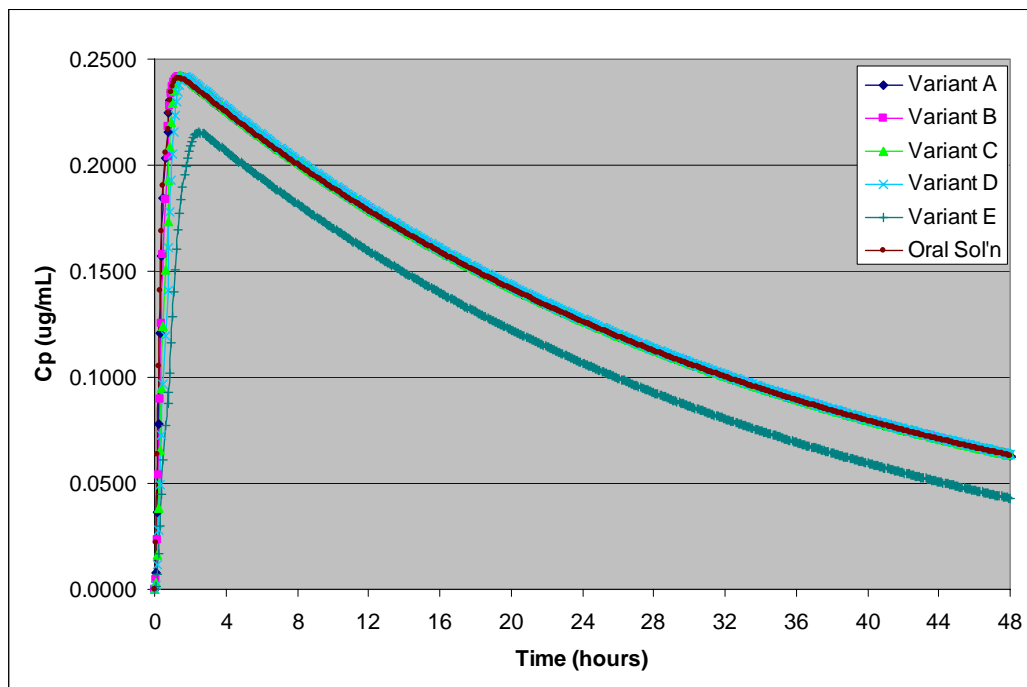

1947

1948

1949 In summary, the *in vitro* dissolution test was able to differentiate between various
 1950 processing and formulation parameters. Therefore, the revised dissolution specification of
 1951 Q = 80% provides a threshold to discriminate between suitable and unsuitable variants.

1952 **4.7 Summary Control Strategy for the ACE Tablets Manufacturing** 1953 **Process**

1954 **4.7.A Overview**

1955

1956 ACE tablets will routinely be the subject of 'Real Time Release' wherein the final product
 1957 quality is ensured through operation within the approved design space. The control
 1958 strategy presented in this section will ensure that input attributes and process parameters
 1959 are maintained within the approved design space and hence that the product meets
 1960 specification without recourse to end product testing. The finished product specification is
 1961 given in Section 8 and final product would meet this specification if tested. Only in the
 1962 case of instrument failure will reversion to end product testing supported by a statistically
 1963 appropriate sampling plan occur.

1964

1965 The development activities have led to an enhanced level of formulation and process
 1966 understanding of critical operations. An initial assessment of each unit operation was
 1967 made using tools such as IPO and Fishbone diagrams, to identify potential variables that
 1968 could impact product quality. A risk assessment was undertaken to identify the variables
 1969 that should be studied further, to fully understand their impact on product quality.
 1970 Multivariate analysis was used to understand the relationship between the variables and
 1971 the drug product quality attributes. A control strategy was then defined to ensure that the
 1972 output of the unit operation met the requirements of onward processing steps and the drug
 1973 product CQAs. The initial overall risk assessment updated in line with the process
 1974 understanding obtained is given in **Table 31**.

1975

1976 **Table 31: Overall Risk Assessment Updated in line with Process Understanding**
 1977 **Developed**

1978

	Variables and Unit Operations					
DP CQAs	Formulation Composition	Blending	Roller Compaction	Milling	Lubrication	Compression
Appearance	Low	Low	Low	Low	No. of revolutions	Control of tablet hardness
Identity	Low	Low	Low	Low	Low	Low
Assay	Low	Low	Low	Low	Low	In line control of tablet weight and tablet weight uniformity
Impurities	Excipient Compatability	Low	Low	Low	Low	Low
Content Uniformity	Choice and level of Excipients and excipient particle size	Blend uniformity controlled by NIR	No issue within the ranges studied	Granule SA controlled	Low	In line control of tablet weight and tablet weight uniformity
Dissolution	API particle size, choice and level of excipients	Low	Ribbon Density controlled by NIR	Granule SA controlled	No. of revolutions	Control of tablet hardness

1979

1980

1981 Low risk based on prior knowledge

1982 Control Strategy applied to high risk to mitigate risk

1983 High risk

1984

1985 **Table 32** summarizes the overall design space for ACE tablets. The first part of the table
 1986 illustrates that formulation component adjustment may be made to account for the particle
 1987 size distribution of the ingoing API. The design space elements for the blending and roller
 1988 compaction are based largely on ensuring that the output material attributes are within
 1989 pre-defined ranges of blend uniformity and relative ribbon density. There are no design
 1990 space elements proposed for the lubrication step as it has been shown to be non-critical.
 1991 The compaction process can accommodate the range of input variables from the previous

1992 unit ops and the compaction process parameters are adjusted to ensure the output material
 1993 attributes of hardness and weight meet the pre-defined ranges.

1994 **Table 32: Summary of overall Design Space for ACE tablets**

1995

Formulation, blending, compaction and milling parameters		
Acetriptan particle size	d ₉₀ 10-35 microns	d ₉₀ 35-40 microns
Acetriptan concentration	10%	10%
Microcrystalline cellulose (MCC)	40% (intragranular)	40% (intragranular)
MCC particle size (d ₅₀)	30 - 90 micron	30-90 micron
Croscarmellose level	3-4%	3-4%
Lactose monohydrate	38.75 - 40.75%*	39.00 – 40.75%*
Lactose particle size (d ₅₀)	70 – 100 micron	70 – 100 micron
Talc	5%	5%
Mg Stearate level	1-2% (intragranular) 0.25% (extragranular)	1-1.75% (intragranular) 0.25% (extragranular)
Blender	Any diffusive blender	Any diffusive blender
Humidity	20-70% RH	20-70% RH
Relative ribbon density	0.68-0.81	0.68-0.81
Granule GSA (cm ² /100g)	12,000-41,000	12,000-41,000
Hardness (kN)	5 -12	5-12
Mean core weight 20 cores	194-206mg	194-206mg
Individual core weights	190-210mg	190-210mg
Scale	Any	Any
Site	Any certified site using equipment of same principles	Any certified site using equipment of same principles
*Quantity adjusted to compensate for amount of croscarmellose sodium and/or magnesium stearate used in order to ensure 200mg overall tablet weight.		

1996

1997 The control strategy is designed to ensure that the manufacturing process operates
 1998 reproducibly within the above design space. **Figure 47** provides a high level overview of

1999 the control strategy developed for ACE tablets. The diagram shows which unit operations
 2000 impact each drug product CQA, the control points, control method and the intermediate
 2001 quality attributes controlled.

2002 **Figure 47: Control Strategy for CQAs for ACE Tablets**

2003

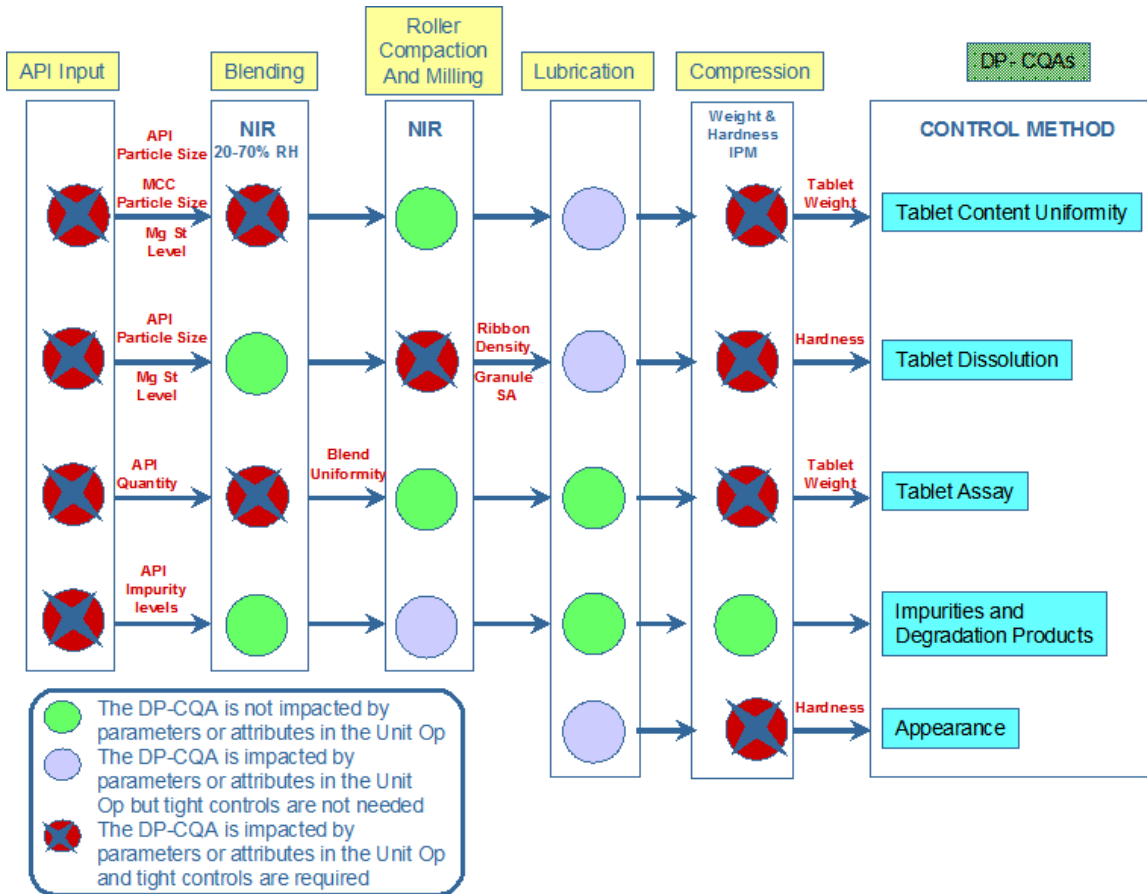

2004
 2005

2006 **4.7.B Unit Operation Control Strategy**

2007

2008 An overview of the control strategy for each critical unit operation is described below.

2009 The control strategy for each unit operation assumes that the control strategy for all

2010 previous unit operations has been followed.

2011 **Blending**

2012 The control strategy for blending is summarized in **Figure 48** below. The parameters that
 2013 can significantly affect the blending process are environmental humidity, particle sizes of
 2014 the API, microcrystalline cellulose and lactose and magnesium stearate level. It is
 2015 proposed that NIR be used for routine determination of the endpoint of the blending
 2016 process. Because NIR monitoring of the blend uniformity ensures that adequate mixing is
 2017 performed, it obviates the need to specify any of the input process parameters such as

2018 rotation speed, time, scale, excipient sources, environmental humidity or equipment
 2019 (provided a diffusive blender is employed). The blend operation will be terminated when
 2020 blend uniformity is first achieved, as indicated by NIR, to avoid segregation.

2021
 2022 However, in the event of the NIR instrument failing, where acetriptyan of a previously used
 2023 particle size is employed, the input parameters recorded in previous batches will be used
 2024 for blending. Release of the finished batch will then require appropriate sampling
 2025 followed by end product testing according to the approved specification.

2027 **Figure 48: Control Strategy for Blending**

2028

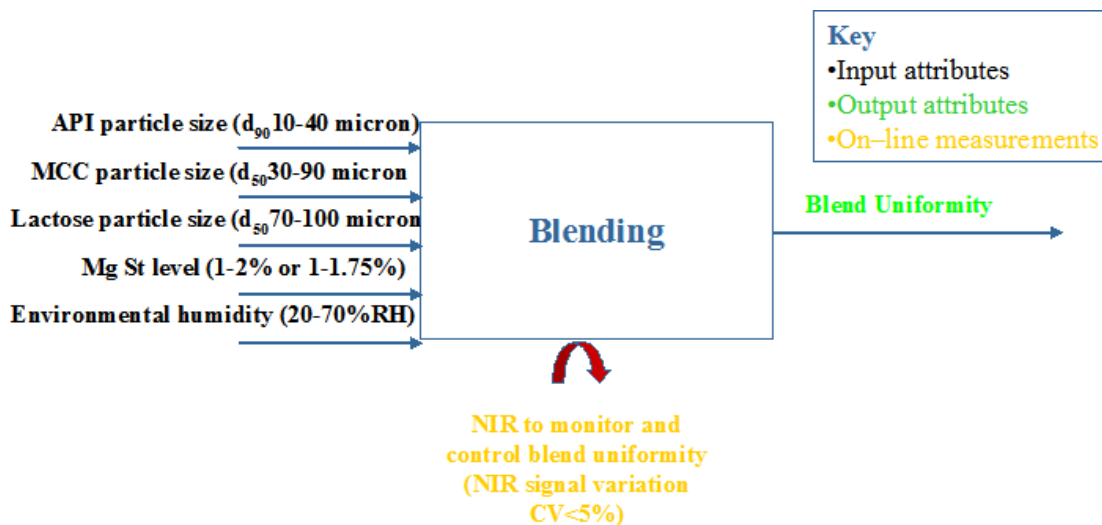

2029
 2030

2031 **Roller Compaction and Milling**

2032 The control strategy for roller compact is summarized in **Figure 49** below. The control
 2033 strategy is based on producing ribbon with relative density 0.68 to 0.81, in order to deliver
 2034 acceptable tablet attributes of hardness and dissolution. NIR is used as a real time
 2035 surrogate measure for ribbon density to detect any variability, with manual or automated
 2036 intervention as required to alter the process to achieve the required ribbon density.

2037
 2038 For milling the mill screen size and speed will be selected to ensure that the Granule
 2039 Surface Area remains within the proven ranges (12,000-42, 000 cm²/100g).

2040
 2041

2042 **Figure 49: Control Strategy for Roller Compaction**

2043

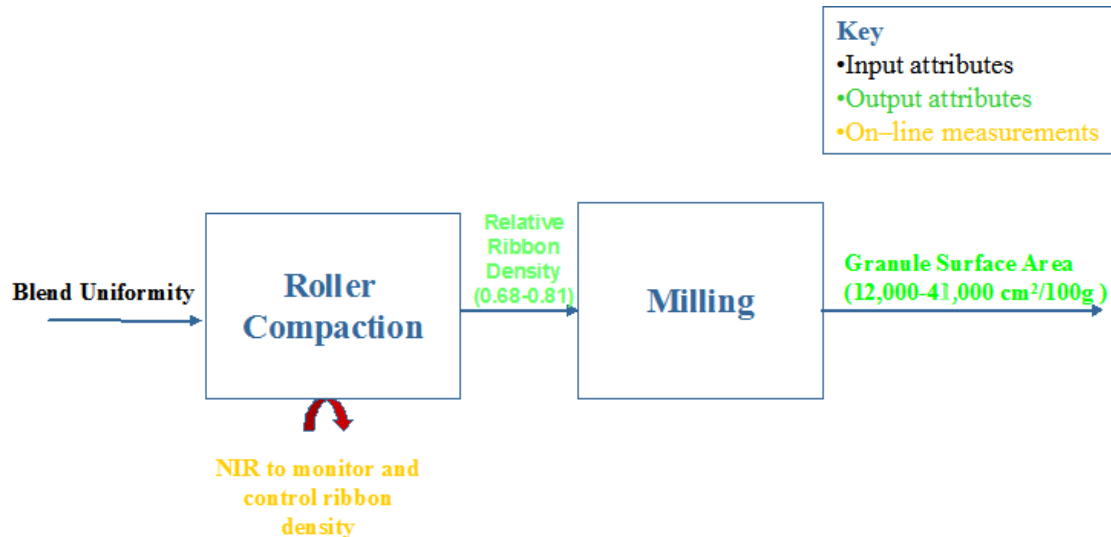
 2044
 2045

 2046 **Lubrication**

 2047 Since NIR on the blender is not capable of fully measuring the lubrication process (i.e.
 2048 over-lubrication), a traditional method (fixed blending range based on a number of
 2049 revolutions) is used to establish the end-point of blending.
 2050

 2051 **Tablet Compression**

 2052 The control strategy for compression is summarized in **Figure 50**. The control strategy for
 2053 compression is to maintain the tablet attributes of hardness and tablet weight within the
 2054 required ranges. The target compression force required to produce tablets with acceptable
 2055 quality attributes is established using the in process measurements at the beginning of the
 2056 run. The compression force is measured throughout the run and compared to the target
 2057 compression force. Deviations from the target compression force result in tablet weight
 2058 corrections by adjusting the fill depth. Upper and lower limits of compression force are
 2059 set and any tablet that registers a compression force outside these limits is automatically
 2060 rejected by the tablet press.
 2061

2062 **Figure 50: Control Strategy for Compression**

2063

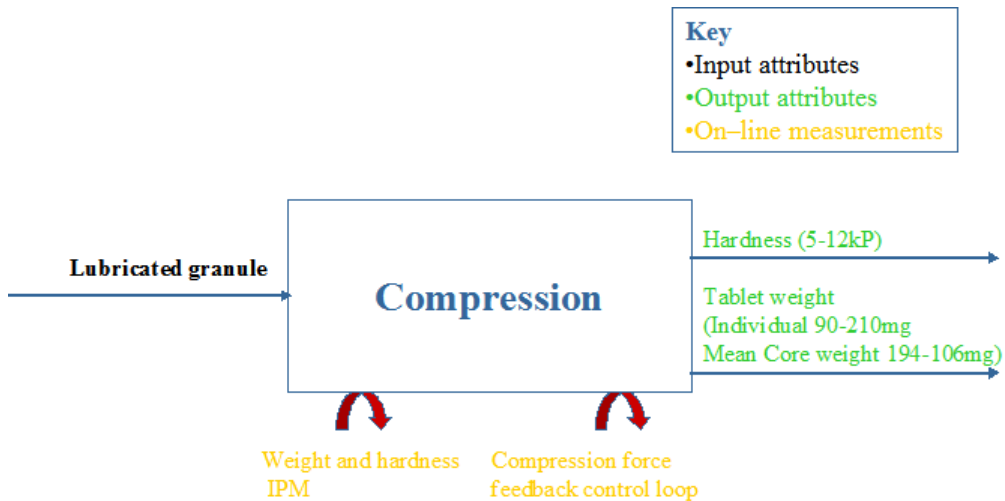

2064

2065

2066

 2067 **4.7.C Control of Drug Product Critical Quality Attributes**

2068

2069 The control strategy for each drug product critical quality attribute is detailed below.

2070

2071 Appearance

 2072 Tablet appearance is impacted primarily by the compression process. The
 2073 compression process is controlled by maintaining the tablet hardness and weight
 2074 within the specified limits. This is achieved through control of compression force
 2075 and weight throughout the compression run using a feedback control loop.

2076

2077 Identity

2078 Controlled at the synthesis stage, see section S.2., and by GMP.

2079

2080 Assay

2081

 2082 Tablet assay is impacted by the amount of acetriptyan that is added at the mixing
 2083 and blending stage and the tablet weight following compression.

2084

 2085 The quantity of acetriptyan added is adjusted based on the acetriptyan assay,
 2086 acetriptyan assay is controlled by the acetriptyan syntheses and the control strategy is
 2087 described in section S.2.

2088

 2089 Tablet weight and weight uniformity are controlled on-line during the compression
 2090 process by a feedback control loop.

2091

2092 Impurities (Degradation Products)

2093 The impurities resulting from synthesis are controlled during the acetriptan
2094 synthesis and the control strategy is described in section S.2.
2095

2096 The levels of individual and total known and potential degradation products were
2097 monitored throughout process development. No increase in degradation products
2098 was observed in ACE tablets, in comparison to the input acetriptan. Based on the
2099 evidence of stability during manufacturing, testing for degradation products will
2100 not be performed at release.
2101

2102 Tablet Content Uniformity

2103
2104 The attributes that must be controlled to control the tablet content uniformity are
2105 API particle size, microcrystalline cellulose particle size, lactose particle size and
2106 magnesium stearate level, blend uniformity following blending and tablet weight
2107 and tablet weight uniformity on compression.
2108

2109 Acetriptan particle size is controlled within specified limits, the control strategy
2110 for API particle size is discussed in section S.2.
2111

2112 Microcrystalline cellulose particle size is controlled by the microcrystalline
2113 cellulose specification.
2114

2115 Lactose particle size is controlled by the lactose specification.
2116

2117 The intra-granular magnesium stearate level is defined based on the acetriptan
2118 particle size.
2119

2120 Tablet Content Uniformity is impacted by the mixing and blending step prior to
2121 roller compaction. Based on process understanding and risk assessment, the
2122 attribute that influences content uniformity has been identified as blend content
2123 uniformity. Uniformity of the blend and blending end-point is monitored and
2124 controlled by NIR. The blend operation will be terminated when blend uniformity
2125 is first achieved, as indicated by NIR, to avoid segregation.
2126

2127 Content uniformity is also impacted by the weight and weight uniformity of the
2128 tablets produced following compression. Tablet weight and weight uniformity are
2129 controlled on-line during the compression process by a feedback control loop.
2130

2131 Dissolution

2132
2133 The attributes that can impact dissolution have been identified as acetriptan
2134 particle size, magnesium stearate level, ribbon density following roller compaction
2135 and tablet hardness on compression.
2136

2137 Acetriptan particle size is controlled within specified limits, the control strategy
2138 for particle size is discussed in section S.2.

2139
2140 The roller compaction process is controlled by monitoring and controlling the
2141 ribbon density using NIR.

2142
2143 The compression process is controlled by maintaining the tablet hardness within
2144 the specified limits. This is achieved through control of compression force
2145 throughout the compression run using a feedback control loop.

2146
2147 Microbiology

2148
2149 No testing of ACE tablets is deemed to be necessary (see Section 5).

2150

2151 **4.7.D Control Strategy Conclusion**

2152
2153 Assuming the control strategy, as outlined above, is followed the tablets will be released
2154 without recourse to end product testing (Real Time Release).

2155
2156 In the case of failure of any of the on-line monitoring systems, process conditions
2157 previously demonstrated to provide satisfactory performance will be used, and a
2158 statistically appropriate sampling plan coupled with additional testing will be utilized to
2159 ensure the quality of the batch is acceptable..

2160 **5. Container Closure System**

2161
2162 ACE tablets are packaged into 30cc HDPE bottles containing cotton wadding and a heat-
2163 induction seal, closed with polypropylene caps (10 tablets per bottle) and Aclar blisters
2164 with push-through foil lidding (20g/cm²), 6 tablets per blister, and contained within a
2165 cardboard carton. Stability data can attest to the suitability of these container closure
2166 systems.

2167 **6. Microbiological Attributes.**

2168
2169 Water activity for ACE tablets was measured on three primary stability batches and all
2170 results were below 0.4. A water activity of greater than 0.9 is required for the survival of
2171 most pathogenic bacteria and a water activity of greater than 0.6 is the physiological
2172 minimum required for the proliferation of any known microorganisms (Baird, R.M., ed.,
2173 *Microbiological Quality assurance in Cosmetics, Toiletries and Non-Sterile*
2174 *Pharmaceuticals*. Bristol. PA. 121-123)

2175
2176 The excipients used in the manufacture of ACE tablets are tested for microbial growth
2177 according to the USP.

2178

2179 Microbiological testing will not be routinely undertaken for ACE tablets due to the
 2180 extremely low water activity of the product and controls on the incoming raw materials.
 2181 However, microbiological acceptance criteria are included on the specification for ACE
 2182 tablets and the tablets would meet this specification requirement, if tested.

2183 **7. Summary of the Manufacturing Procedure**

2184 **7.1 Manufacturing Formula for ACE 20 mg Tablets**

2185
 2186 The manufacturing formula for ACE 20 mg tablets is presented in **Table 33**. This is
 2187 reflective of a nominal 100 kg scale. Because roller compaction, milling and compressing
 2188 are continuous unit operations, batch size is related to the time the equipment is in
 2189 operation and therefore, a wide range of batch sizes can be made without a change in
 2190 scale of the equipment. In addition, the design space is presented as scale independent
 2191 where possible. Although the blending and lubrication unit operations are not continuous,
 2192 and therefore, different scales of equipment might be used for different batch sizes, the
 2193 scientific understanding presented, shows that ,provided the defined control strategies are
 2194 in place, changes to scale should be considered as movement within the design space.
 2195 Therefore, variation in the scale of product manufacture is considered acceptable,
 2196 provided that, the operation is conducted within the company’s quality systems and the
 2197 manufacturing control strategy is utilized.

2198

2199 **Table 33: Manufacturing Formula for ACE 20 mg Tablets**

Ingredients	Quantity per 100 (kg)
<u>Active Substance</u>	
ACE	10.0
<u>Intragranular Excipients</u>	
Microcrystalline Cellulose	40.0
Lactose Monohydrate	38.75-40.75*
Croscarmellose Sodium	3-4
Magnesium Stearate	1-2
<u>Extragranular Excipients</u>	
Magnesium Stearate	0.25
Talc	5.0
Total	100.0

2200 * Quantity adjusted to compensate for amount of croscarmellose sodium and/or magnesium stearate used in
 2201 order to maintain the same total quantity of material.
 2202

2203 **7.2 Description of Manufacturing Process and Process Controls for**
 2204 **ACE, IR Tablets**

2205 **Introduction**

2206 The following section will describe the manufacturing process for ACE tablets. Each
 2207 tablet contains 20 mg of Drug Substance (Acetripitan).

2208 **7.2.A Process Flow Diagram**

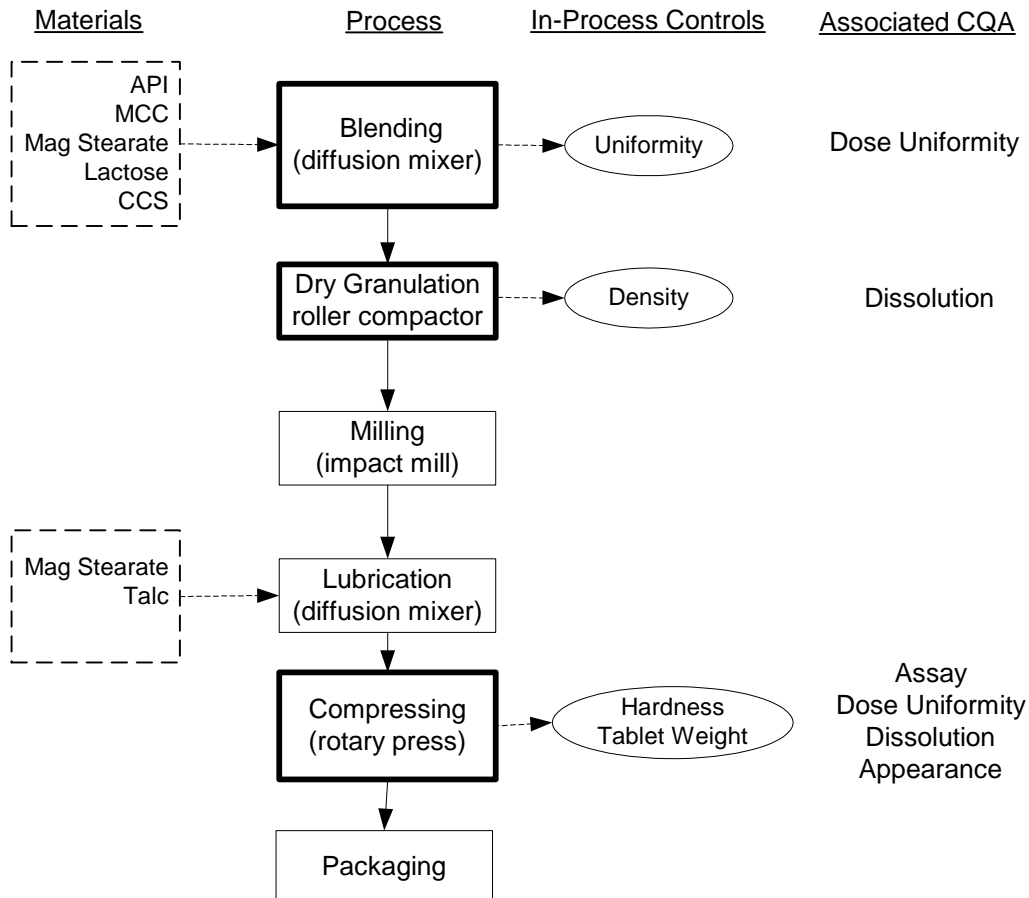

2209

2210 Unit operations with bold borders impact critical quality attributes.

2211 **7.3 Description of Manufacturing Process**

2212 The manufacturing process for ACE tablets can be divided up into 6 separate
 2213 manufacturing steps. These are: (1) Blending, (2) Dry Granulation, (3) Milling, (4)
 2214 Lubrication, (5) Compression, and (6) Packaging. The critical steps are blending, dry
 2215 granulation and compressing. The enhanced process understanding has enabled a design
 2216 space to be built around these processes and gain operational flexibility in order to
 2217 facilitate continuous improvement.

2218 Blending

2219 The purpose of the blending step is to produce a homogenous powder mixture of drug
2220 substance and excipients that is fed into the downstream dry granulation process. Drug
2221 substance and excipients are charged into a diffusion mixer. There is not a specified order
2222 of addition. The mixture is blended until homogeneity is obtained and then is stopped to
2223 ensure no de-mixing occurs. The environment should be maintained between 20% and
2224 70% relative humidity. Homogeneity will be verified by utilizing an on line spectroscopic
2225 technique. The endpoint of the online technique will be a %CV of NMT 5 with a moving
2226 window size of NLT 10 revolutions.

2227 Dry Granulation

2228 The purpose of the dry granulation unit operation is to provide material that is suitable for
2229 the subsequent compressing operation. Dry granulation is achieved using a roller
2230 compactor that produces ribbons of material that are subsequently milled to the desired
2231 particle size for compaction. As discussed in Section 4.3, ribbon density is the important
2232 attribute of the material during this step. Ribbon density will be maintained within the
2233 range of 0.68-0.81. Density is monitored on-line by NIR and is controlled by adjusting
2234 the roller pressure.

2235 Milling

2236 The purpose of the milling step is to produce a powder with acceptable flow properties for
2237 downstream processing. The ribbon is fed to an impact mill with a screw feeder and is
2238 milled through a screen to ensure a granule surface area within the range 12,000 to 41,000
2239 cm²/100g.

2240 Lubrication

2241 The purpose of the lubrication step is to ensure the milled material runs smoothly on the
2242 compression machine. There is not a specified order of addition for the talc or magnesium
2243 stearate. The product is blended using a diffusion mixer for a targeted number of
2244 revolutions (e.g. 75 revolutions)

2245 Compression

2246 The lubricated product is compressed into tablets with a target weight of 200 mg and
2247 average hardness between 5-12 kP. After tablets with target weight and hardness are
2248 obtained as part of the compressing machine set-up, the distance between the upper and
2249 lower punches is fixed and this sets the target compression force. The compression force
2250 is measured throughout the compression run and compared to the target compression
2251 force and tablet weight for the batch. Deviations from the target weight are corrected by
2252 adjusting the fill depth.
2253

2254 **7.4 Primary packaging**

 2255 The tablets are packaged into HDPE bottles with polypropylene caps and Aclar blisters
 2256 with push-through foil lidding.

 2257 **8. Control of Critical Steps and Intermediates for ACE**
 2258 **Tablets**

 2259 This section describes the control measurement conducted for each of the identified
 2260 critical unit operations, the general test methodology and the acceptance criteria. The
 2261 justification for the information provided in this section is contained in Section 3.
 2262 Table 34 lists the critical process steps and critical intermediates identified and the
 2263 controls that are used to mitigate risk to product quality. Should future knowledge indicate
 2264 that changes are required to these controls, then they will be the subject of an appropriate
 2265 regulatory filing. The controls of all other steps may be adjusted to ensure that the unit
 2266 operations produce appropriate output(s): these adjustments will be managed within the
 2267 company's quality system.
 2268

 2269 **Table 34. Critical Process Steps and associated Intermediates**

Unit Operation	Intermediate Attributes	Measurement Methodology	Acceptance Criteria
Blending	Homogeneity	Spectrometric	%CV NMT 5
Granulation	Density	Spectrometric	0.68-0.81 g/cm ³
Tablet Compression	Tablet Hardness Weight	5-tablet measurement On-line Weight Control	5-12 kP Mean of 20 Tablets within 194-206mg

2270

 2271 **8.1 Control of Drug Product**

 2272 **8.1.A Specification for ACE 20 mg Tablets**

 2273 The specification for ACE 20 mg tablets is presented in Table 35. The specification
 2274 relates to the criteria that the product will meet if sampled from the field and then tested.
 2275 Tablets will not be specifically tested against this specification at the time of manufacture
 2276 except in the case of failure of the on-line NIR used to measure blend uniformity. The
 2277 manufacturing control strategy together with the knowledge of how the product changes
 2278 upon storage ensures that the tablets will meet these criteria through the proposed shelf
 2279 life.
 2280

2281 **Table 35. Specification for ACE 20 mg Tablets**

Test	Acceptance Criteria	Analytical Procedure
Description	White to off-white, round unilaterally convex tablets embossed with ACE and 20	Visual inspection
Identification: Acetripitan free base	Concordant with reference standard.	IR
Content: Acetripitan free base	90.0% – 110.0%	HPLC
Impurities ACE12345	Not more than 0.5%	HPLC
Any other degradation product	Not more than 0.2%	
Total degradation products	Not more than 2.0%	
Uniformity of Dosage Unit	Content Uniformity per JP	JP
Resistance to Crushing	5-12kP	Ph Eur
Dissolution	Q = 80% in 30 minutes per USP Acceptance Table 1	USP App 2, HPLC
Microbial Quality: Bacteria	Category 3A Not more than 10 ³ /g	Ph. Eur.
Fungi	Not more than 10 ² /g	
Escherichia coli	None/g	

2282